

# Speedframe

 STRATCO



## WHY USE THE SPEEDFRAME SYSTEM?

The most important time to get things right is when building a new home, even in the less obvious areas. Quality, reliability, performance, and economy are an essential part of your new investment. Stratco Speedframe is manufactured from high quality materials and is accurately roll formed to produce a

smooth aesthetically pleasing design. It features internally welded corners which provide the best finish possible, and an integrated architrave with fine curved edges. Refined and precise mitres allow for a free flowing, attractive corner. It is attention to detail that gives the Speedframe its quality finish.

## STANDARD DOOR FRAME

All Standard Stratco Speedframes are supplied with quality hardware such as zinc plated butt hinges, a stainless steel striker plate, rubber buffers to reduce any noise and vibration and 4mm brick ties for a secure installation. A stud frame clip is also available for stud wall framing. In addition, two temporary spreader bars are provided to ensure the Speedframe is kept square during transportation.

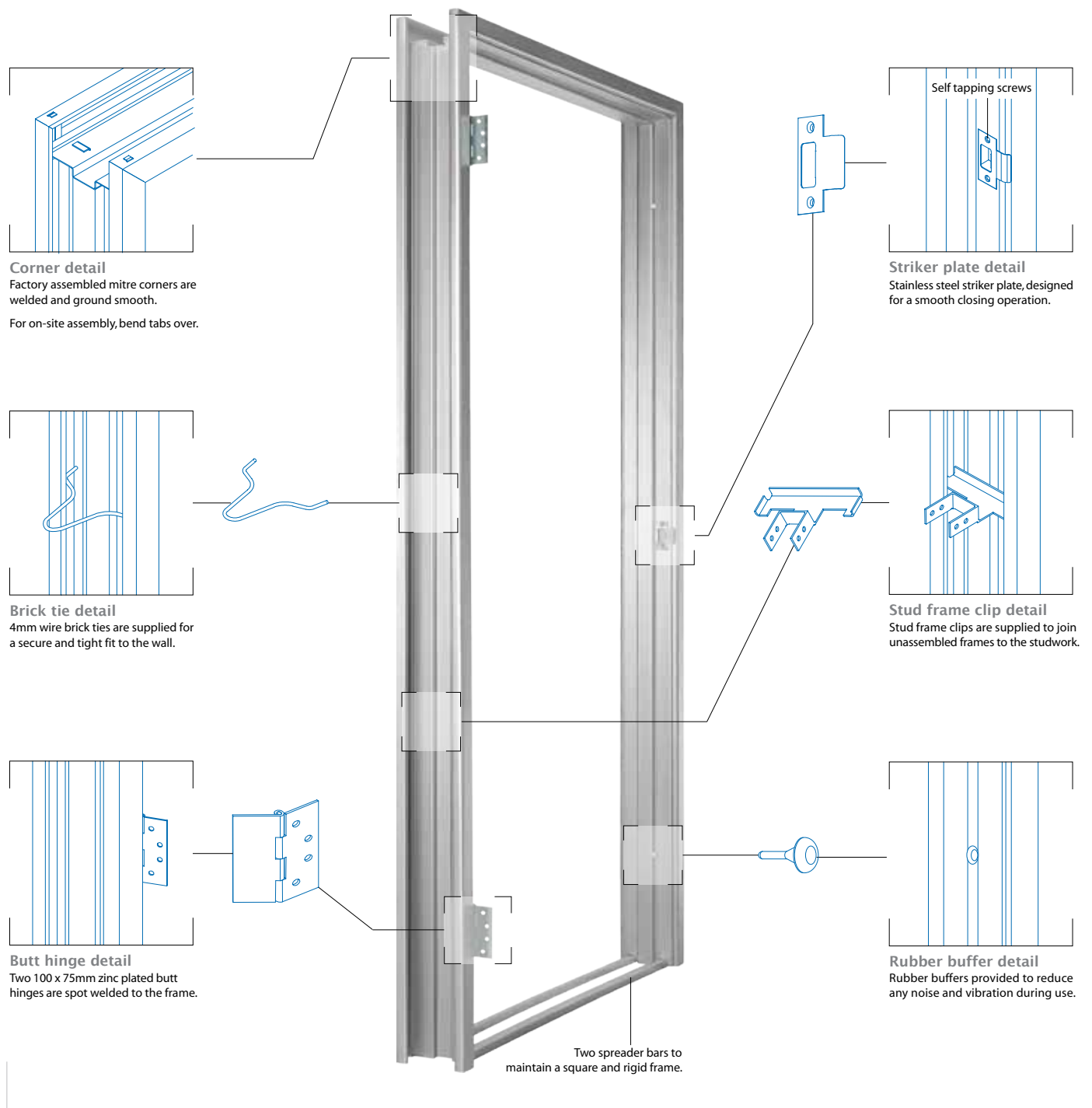
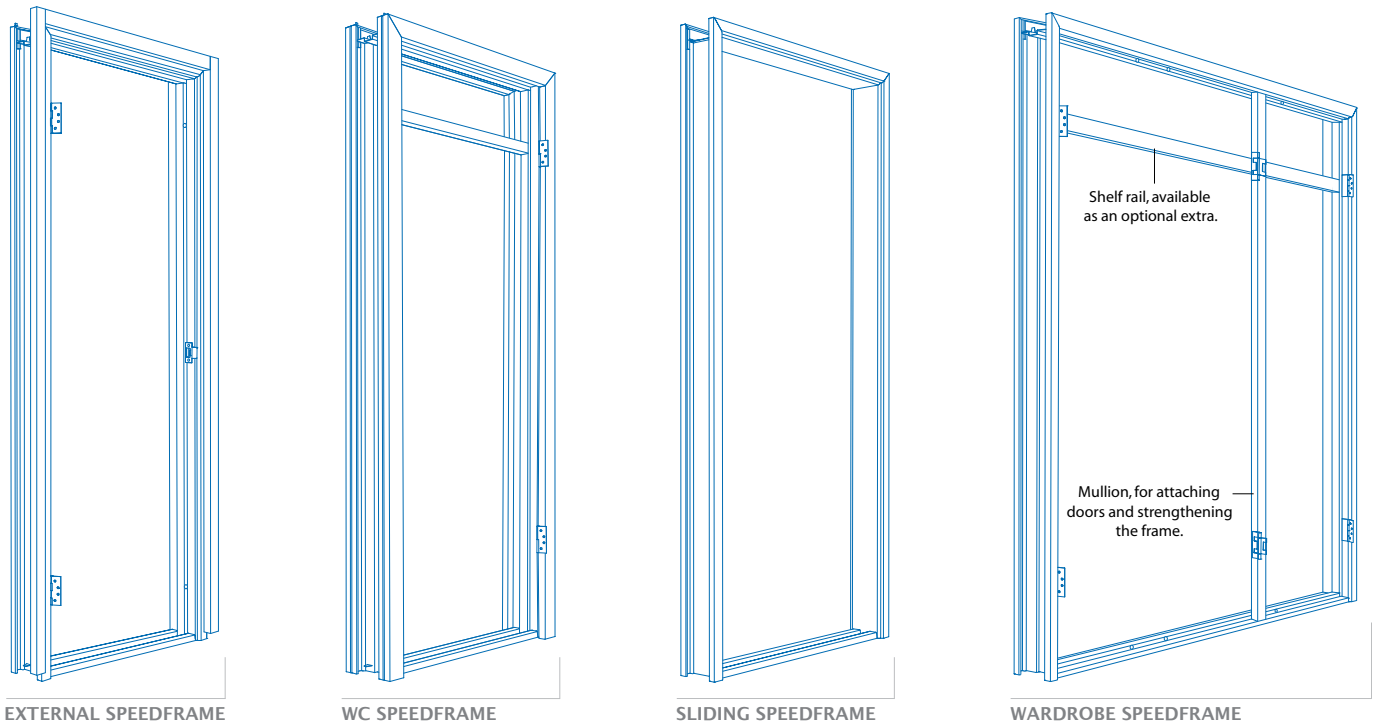

Figure 1.0

# WIDE RANGE

The Stratco Speedframe is available in several formats, these are; the Standard Speedframe, External Speedframe, WC or Water Closet Speedframe, Sliding Speedframe, and the Wardrobe Speedframe. These are available as a complete welded frame or in unassembled form for easy transport. Standard Stratco Speedframes are available in two heights of 2040mm and 2300mm.



## Single Door Frame

Single Speedframes vary in width from 410mm up to 870mm.

## Double Hung Frame

Double Hung Speedframes are available in a range of widths from 820mm up to 1640mm.

## Double Hung Rebate Frame

Double Hung Rebate Speedframes allow for a 10mm overlap in the width of the two doors. They are available in a range of widths from 1030mm up to 1630mm.

## External Frame

External Speedframes are fitted to double leaf external walls and have a flashing welded to the frame in order to cover the cavity between the two walls. The External Speedframe range covers Single, Double Hung and Double Hung Rebate doors. They are all available in 2040mm heights and in varying widths.

## WC Frame

The WC or Water Closet Speedframe comes with lift off hinges and an extra depth head. The frames have a wide range of widths, from 410mm up to 870mm for single size frames.

## Sliding Frame

Sliding Speedframes range in widths of 670, 770 or 870mm.

## Wardrobe Frame

Wardrobe Speedframes are available in combinations of 620mm, 720mm and 820mm wide doors. Stratco can supply wardrobe frames with up to six doors. A wardrobe with three or more doors will require an attached mullion that adds extra strength to the frame.

An option available with the Wardrobe Speedframe is a shelf rail that is welded into the frame at 1700mm above the floor level. All wardrobe frames have a permanent bottom rail attached.

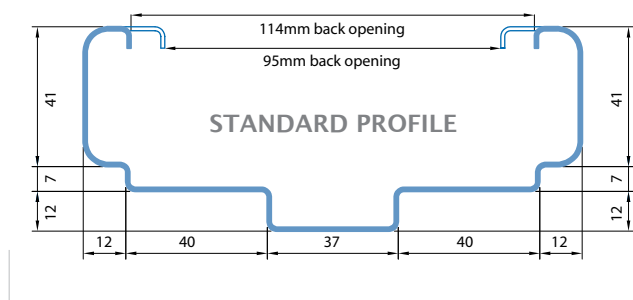

Figure 2.0

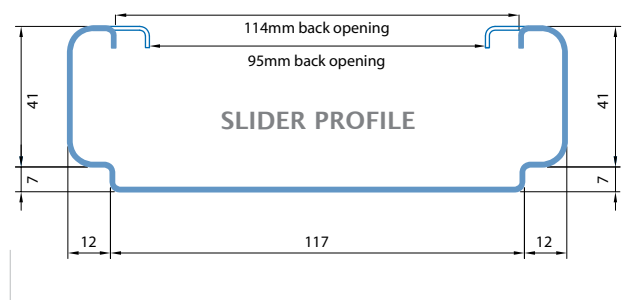

Figure 2.1

STYLE	SPEEDFRAME SIZES AVAILABLE – DOOR WIDTH (mm)																					
	410	420	520	620	670	720	770	820	840	870	1030	1040	1230	1240	1340	1430	1440	1540	1630	1640	1740	
Standard	•	•	•	•		•		•		•												
WC	•	•	•	•		•		•		•												
Sliding					•		•			•					•							•
Double Hung									•			•		•			•				•	
Double Hung Rebate											•		•			•				•		
Wardrobe																						
External Single	•	•	•	•		•		•		•												•
External Double								•	•			•		•			•				•	

All Speedframes are available in 2040mm and 2300mm (excluding external Speedframes). All Speedframes are available in 95mm and 114mm back openings

Table 1.0

## UNASSEMBLED FRAMES

Unassembled Speedframe components are supplied loose to allow for easy on-site assembly into existing brick walls and stud framed walls. Unassembled Speedframes are ideal for country transportation and handling, they are particularly suitable for use in remote communities. Standard, Single and Double Hung door frames are all available in an unassembled form. Included in the package are four mitre joining tabs, these tabs are welded to the inside of the side styles. The head is simply attached on-site by slotting the tabs through the holes that are provided in the head, the tabs are then firmly folded over (figure 3.0), resulting in a strong, clean and tight finish.

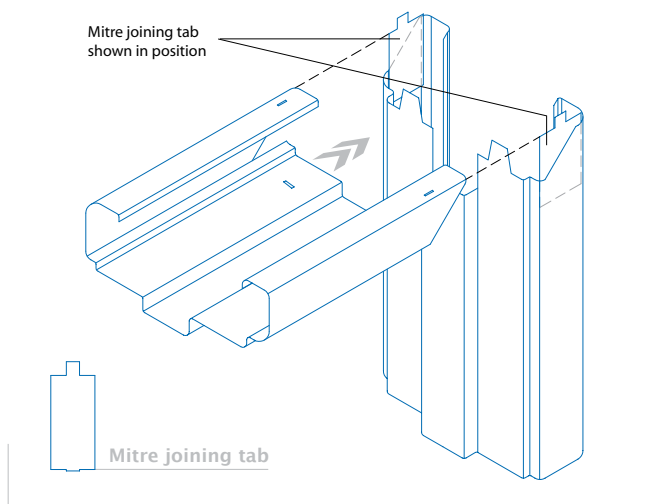

Figure 3.0

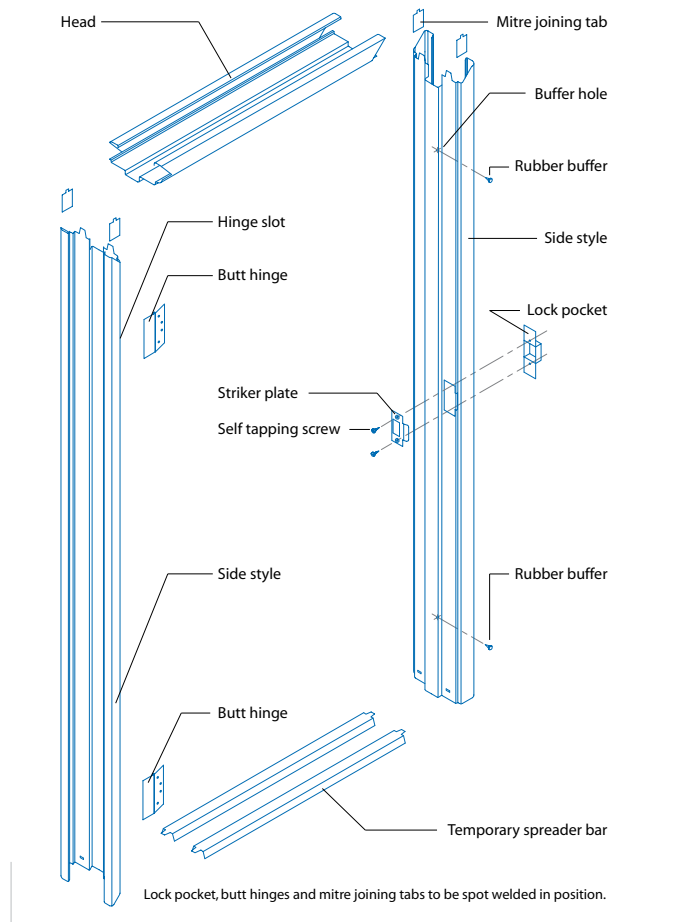

Figure 3.1

## CONSTRUCTION DETAILS

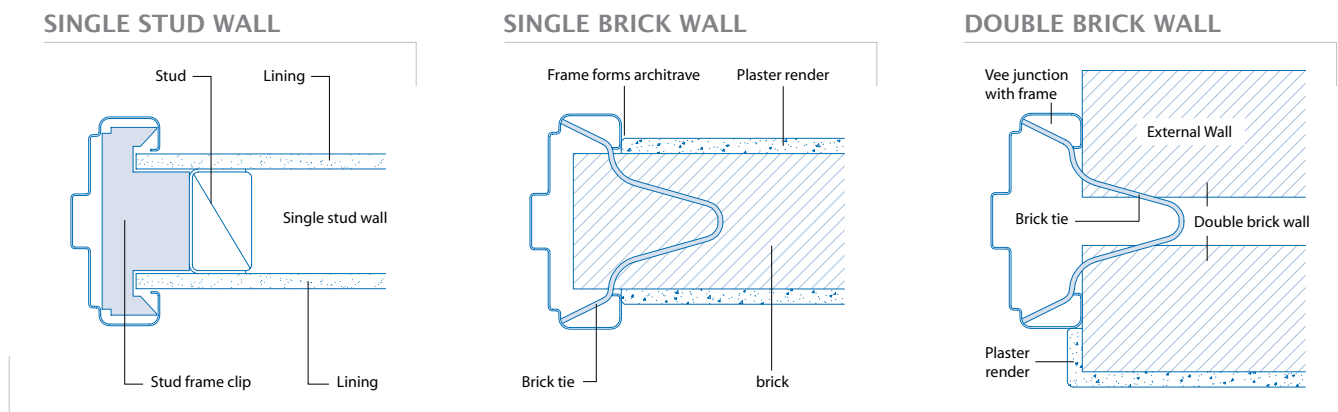
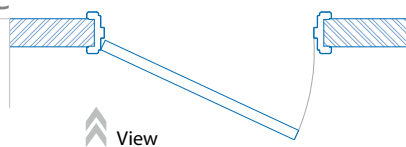

Figure 4.0

## OPENING COMBINATIONS

### STANDARD/WC

Left Hand Opening



### STANDARD/WC

Right Hand Opening

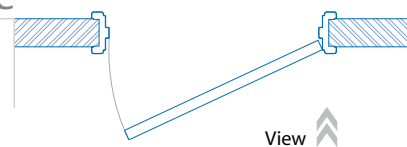
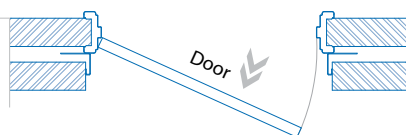

Figure 5.0

### EXTERNAL

Internal Wall



### EXTERNAL

External Wall

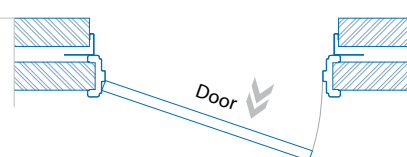

Figure 5.1

### WARDROBE

3 x 820mm Left Hand Combination

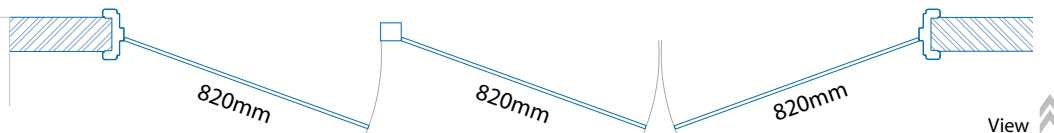

Figure 5.2

## ORDERING INFORMATION

### Specify Back Opening Size

Stratco Speedframes are available in a choice of two back opening sizes. They come with either a 95mm back opening for internal modular brick walls, or a 114mm back opening for standard single brick external walls and feature brick walls. These back opening sizes also suit 75mm and 90mm timber and steel stud frames.

### Left or Right Hand

To order a Speedframe door frame, please nominate whether the door will be opening from the left or right hand side. When determining the side of the door opening, stand facing the door with the door opening towards you. The side with the hinges on it is the nominated side, see figure 5.0.

### Standard and WC Door Frames

When ordering a Standard door frame, specify the door height followed by the door width, for example 2040mm x 820mm. The Speedframe supplied by Stratco will be 20mm higher and 3mm wider than the size of the door, i.e. 2060mm x 823mm.

### External Door Frames

Additional information is required for ordering an External door frame. As well as specifying the door height and width, you will also need to nominate whether the frame is to be fitted to the internal or external leaf, if the door is left or right hand, and if the door opens inwards or outwards. The Speedframe supplied by Stratco will still be 20mm higher and 3mm wider than the size of the door. It will also have a flashing welded to the frame to cover the cavity.

### Sliding Door Frames

When ordering a Sliding door frame, please specify the door height followed by the door width, for example 2040mm x 870mm. The Speedframe supplied by Stratco will be 20mm higher and 47mm less in width than the door, i.e. 2060mm x 823mm. Similarly, for double sliding doors 2040mm x 1640mm, the Speedframe supplied will be 2060mm x 1593mm.

### Double Hung Frames

When ordering a Double Hung door frame, specify the height and total width of the two doors, for example 2040mm x 1640mm. The Speedframe supplied, will be 20mm higher and 5mm wider than the size of the doors, i.e. 2060mm x 1645mm.

### Double Hung Rebate Frames

When ordering a Double Hung Rebate door frame, please specify the height and total width of the two doors, for example 2040mm x 1630mm. The Speedframe supplied by Stratco will be 20mm higher and 5mm wider than the size of the doors, i.e. 2060mm x 1635mm.

### Wardrobe Frames

When ordering a Wardrobe door frame, specify the height, width and number of doors, and if a single door is present whether it is left or right hand. For example, a wardrobe with three 820mm wide doors with the single door on the right hand side would be specified as 2040mm x 3/820mm RH wardrobe. The Speedframe supplied by Stratco will be 20mm higher and 3mm wider for each door leaf, i.e. 2060mm x 2469mm with the single door hung from the right hand stile, see figure 5.2.

## CONTACT

**1300 165 165**

## SPECIFICATIONS

### Material

Stratco Speedframes are manufactured from 1.1mm BMT (base metal thickness), annealed, zinc coated steel. Minimum coating is to be G2S ZF100 (100 grams per square metre, total of both sides).

### Profiles

Single frame Speedframes are available in both standard profile and slider profile while Double Hung, Double Hung Rebate, WC, External and Wardrobe Speedframes are available in standard profile only.

### Hinges

Two 100 x 75mm zinc coated, broad butt hinges are supplied per door, per frame.

### Striker Plate

A steel striker plate, manufactured from .8mm, 304 2B grade stainless steel is positioned 1035mm above floor level, attached by two 6 gauge x 12mm zinc plated self tapping screws.

### Rubber Buffers

Standard, External and WC Speedframes are supplied with two rubber buffers for each frame while Wardrobe Speedframes are supplied with two per door, per frame.

### Spreader Bars

Spreader Bars are manufactured from 1.1mm BMT annealed, zinc coated steel, minimum coating to be G2S ZF100. Two temporary bars are supplied per frame except for Wardrobe frames which have a permanent bottom rail attached.

### Wall Ties

Speedframes are supplied with eight 4mm wire brick ties per frame. Alternatively, stud frame clips can be supplied for attaching to steel or timber framed walls.

### Painting

Before painting the door frame it is necessary to wash off any dirt with water and wipe off greasy deposits with paint thinner. Stratco Speedframes are made from anneal treated steel to provide a corrosion resistant surface finish ready for painting without the need for additional surface treatment such as priming.

## IMPORTANT INFORMATION

While all Stratco Speedframes are zinc coated to minimise corrosion before painting, Stratco Speedframes should not be left exposed to external weather conditions on site for extended periods of time, prior to installation.

## MAINTENANCE REQUIREMENTS

Rubber buffers, hinges and striker plate are all replaceable components, should they become damaged through normal use. All other components of a Stratco Speedframe do not require additional maintenance.

This brochure should be read with the "Selection, Use and Maintenance" Brochure.