

VEUE | WIRE GUIDE INSTALLATION MANUAL

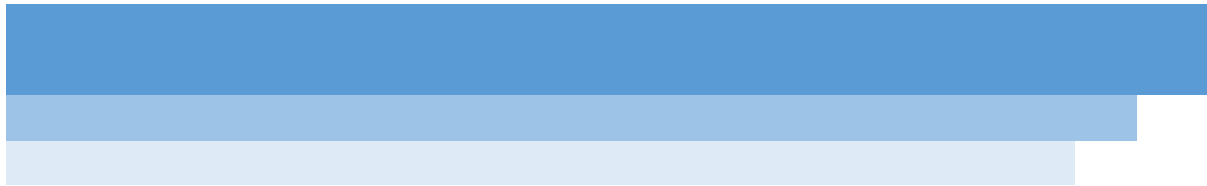

November 2018

CONTENTS

November 2018

This manual is to be read in conjunction with the Product Specifications & Assembly manual

SECTION NO.	DESCRIPTION	PAGE NO.
SECTION 1	– ITEMS REQUIRED	1.1
SECTION 2	– INSTALLATION	2.1
	PART A – PREPARING INSTALLATION SPACE	2.1
	PART B – SPRING PRE-TENSIONING	2.2
	PART C – BOX INSTALLATION	2.7
	PART D – COVER INSTALLATION	2.9
	PART E – OPEN BRACKET INSTALLATION	2.11
	PART F – BLIND INSTALLATION	2.13
	PART G – TENSION GUIDELINES	2.20
	PART H – INSERT BOX / COVER	2.25
SECTION 3	– TROUBLESHOOTING	3.1

DISCLAIMER

INTRODUCTION

This Installation manual has been produced by Rollease Acmeda to supply the necessary information for safe and correct installation of this system.

INSTALLERS RESPONSIBILITY

Before installing, please read & ensure you understand the safety information and installation instructions as defined in this installation manual.

- If you do not fully understand these instructions, contact Rollease Acmeda for clarification before installing.
- The Installer is responsible to ensure that all installation personnel have been adequately trained on the safe & correct installation and operation.
- The Installer is responsible to ensure that a Job Safety Analysis or Safe Work Method Statement is completed prior to installation to identify hazards, to determine appropriate risk control measures and to implement the control measures.
- The Installer is responsible to ensure that supporting structures are sound and can adequately support the load.
- The Installer is responsible to ensure that the devices used to anchor the product to the supporting structure are suitable for the application.

SAFETY INFORMATION

- Ensure Job Safety Analysis/Safe Work Method Statement is completed and actions to reduce risks are implemented.
- Ensure that electrical works are done only by a LICENSED ELECTRICIAN.
- DO NOT modify any of the components of this system.

PERSONNEL REQUIREMENTS

Only suitably trained/qualified personnel should undertake installation.

DISCLAIMER

Rollease Acmeda has used reasonable care in preparing the information included in this document, but makes no representations or warranties as to the completeness or accuracy of the information. Information is supplied upon the condition that the persons receiving the information will make their own determination as to its suitability for their purposes prior to use. Rollease Acmeda assumes no liability whatsoever for any damages incurred by you resulting from errors in or omissions from the information included herein. Rollease Acmeda reserves the right to make changes without further notice to any products to improve reliability, function or design.

COPYRIGHT

COPYRIGHT © ROLLEASE ACMEDA 2018

All rights reserved. No part of this document may be reproduced or utilised in any means, by any means, electronic or mechanical including photocopying, recordings, or by any information storage or retrieval system, without the express permission from Rollease Acmeda.

SECTION 1 – ITEMS REQUIRED

TOOLS REQUIRED

- Saw
- Saw
- Drill
- Screw Driver – Philips Head & Flat Head
- Jaw Pliers
- Allen Key Set
- Mallet
- Scissors
- Measuring Tape
- Pencil

ADDITIONAL ITEMS REQUIRED (NOT SUPPLIED)

To assemble an VEUE | WIRE GUIDE, the following non-stocked items are required:

- Fixings for Box/Open Brackets/Hardware (ensure appropriate fixings are used to suit application)
- Trims to conceal packing (if required)

BLIND ITEMS REQUIRED

BOX

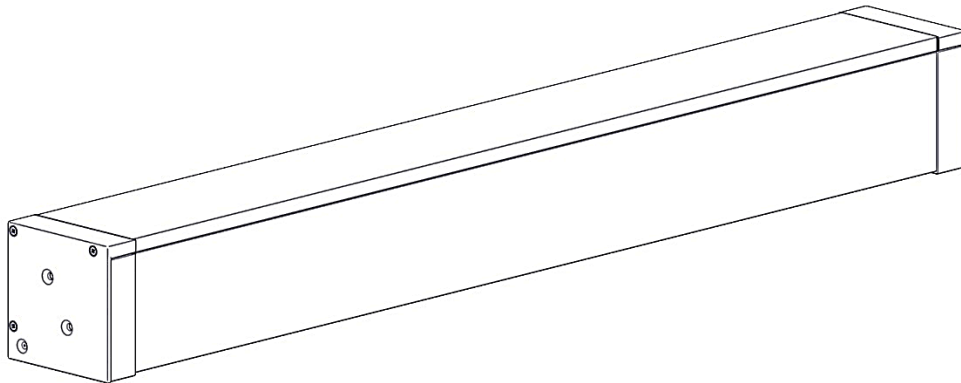

or

COVER

Fascia Bracket (RE03-0101-xxx000)
may be required as a centre support
for larger spans

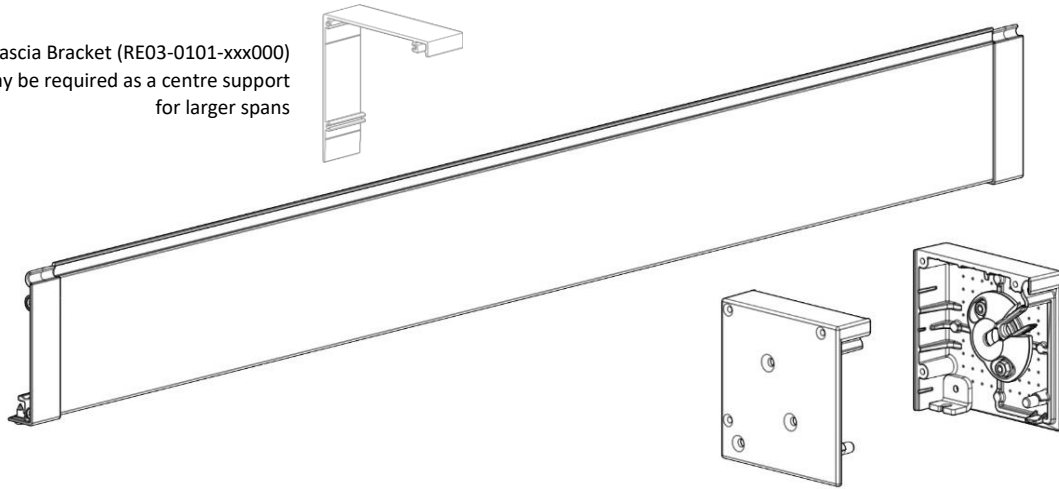

or

OPEN BRACKETS

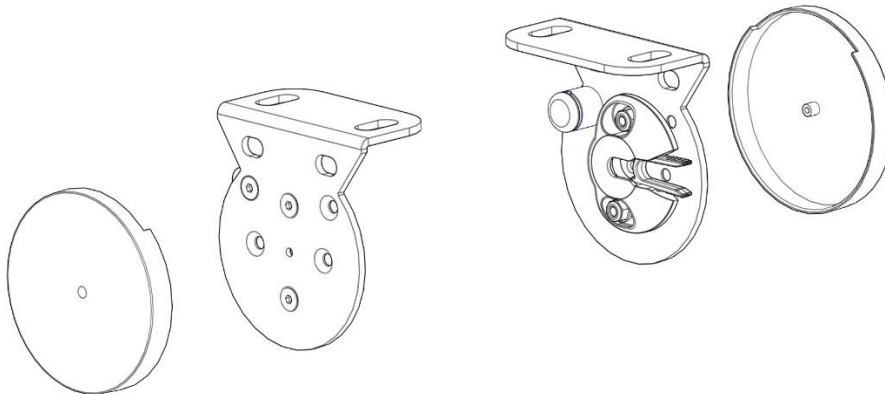

NOTE: Store clip until required (can be left in adaptor as shown)

BLIND

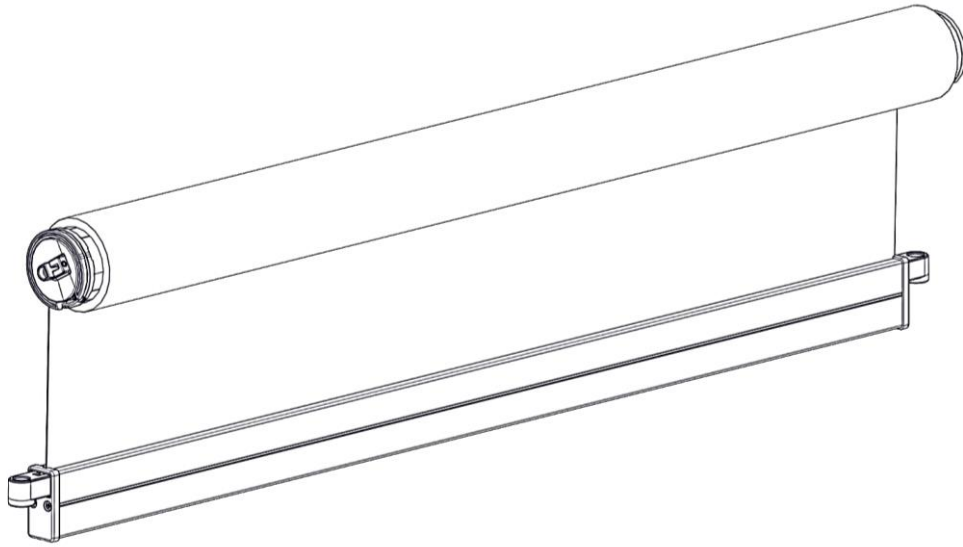

WIRE GUIDE AND FIXING HARDWARE

OPTION 1 – Hook Terminal

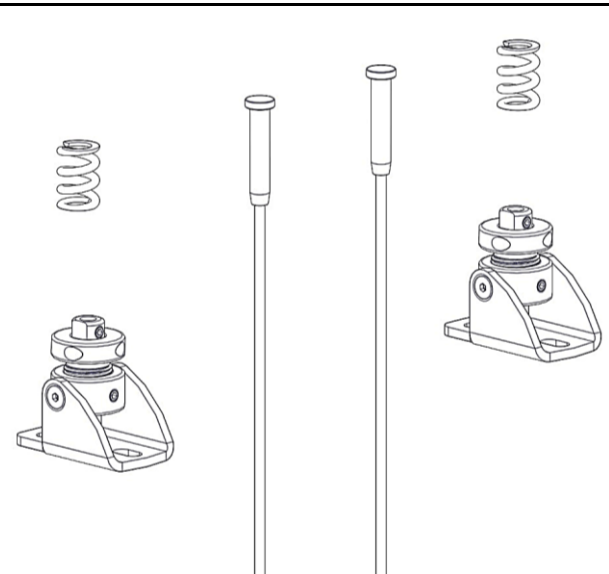

OPTION 2 - Clamp Terminal

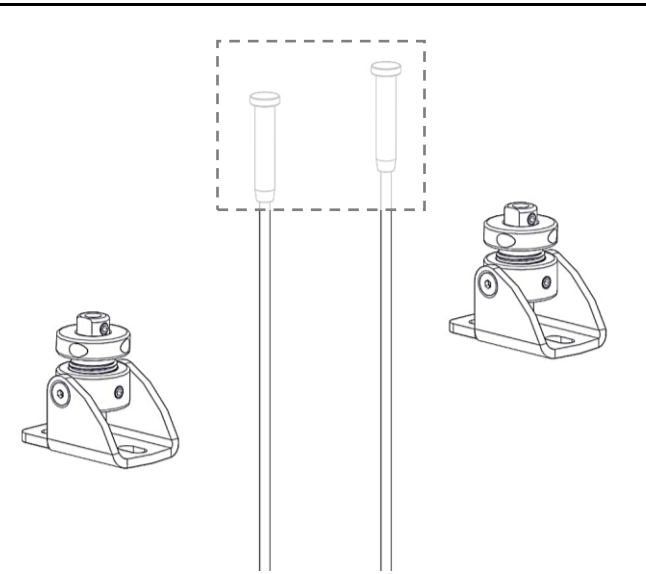

NOTE: Dome terminal must be cut/removed for this option

WIRE GUIDE LOCK

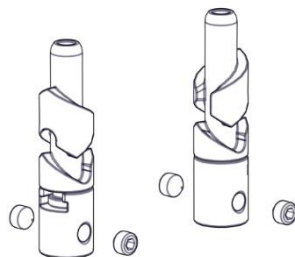

STRAP DOWN HARDWARE

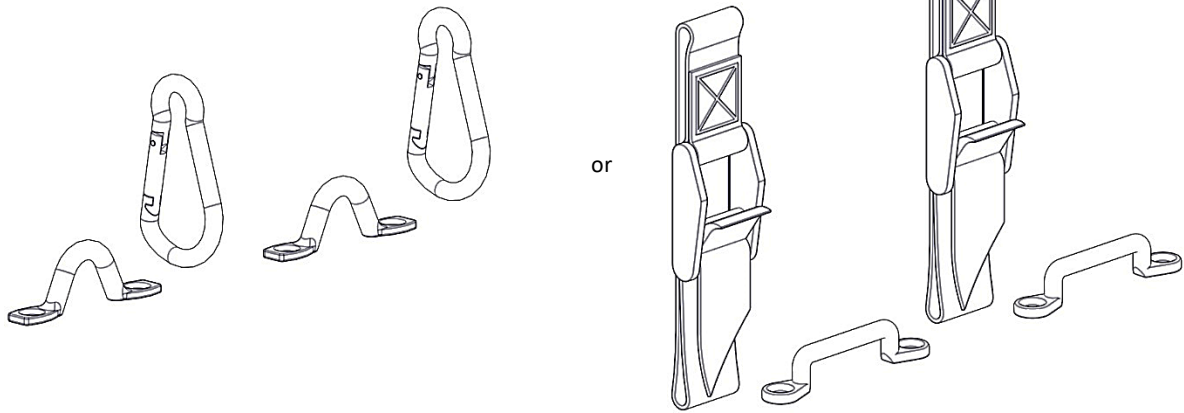

SECTION 2 – INSTALLATION

PART A – PREPARING INSTALLATION SPACE

STEP 1 – CHECK FOR OBSTRUCTIONS

Check for any obstructions that may interfere in installation.

STEP 2 – CHECK VERTICAL & HORIZONTAL INSTALLATION DIMENSIONS

VERTICAL DIMENSIONS

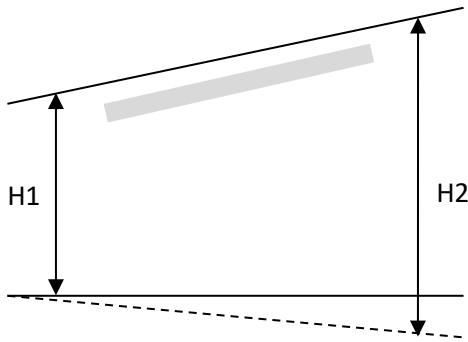

Check if top of installation space is level.

- If $H1 \neq H2$, corrective actions may need to be considered prior to installation

HORIZONTAL DIMENSIONS

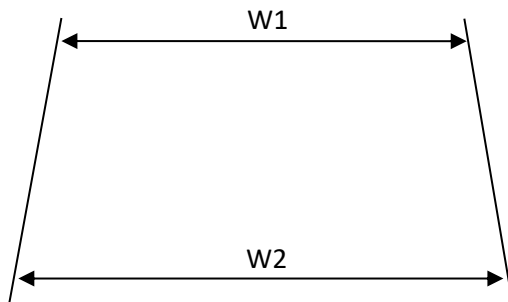

If $W2 \geq W1$, $W1$ =Blind Width
(proceed to Part B)

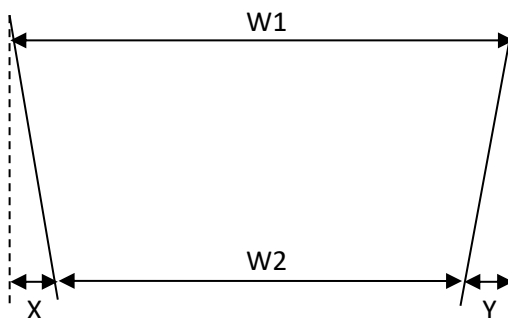

If $W2 < W1$, by a value of:
0-20mm, Proceed to Part B ($W1$ = Blind Width)
20+, Consider corrective action to square installation space

PART B – SPRING PRE-TENSIONING

STEP 1 – IDENTIFY NUMBER OF PRE-TURNS REQUIRED FOR BLIND SIZE

63mm TUBE [F56 Weight Bar]

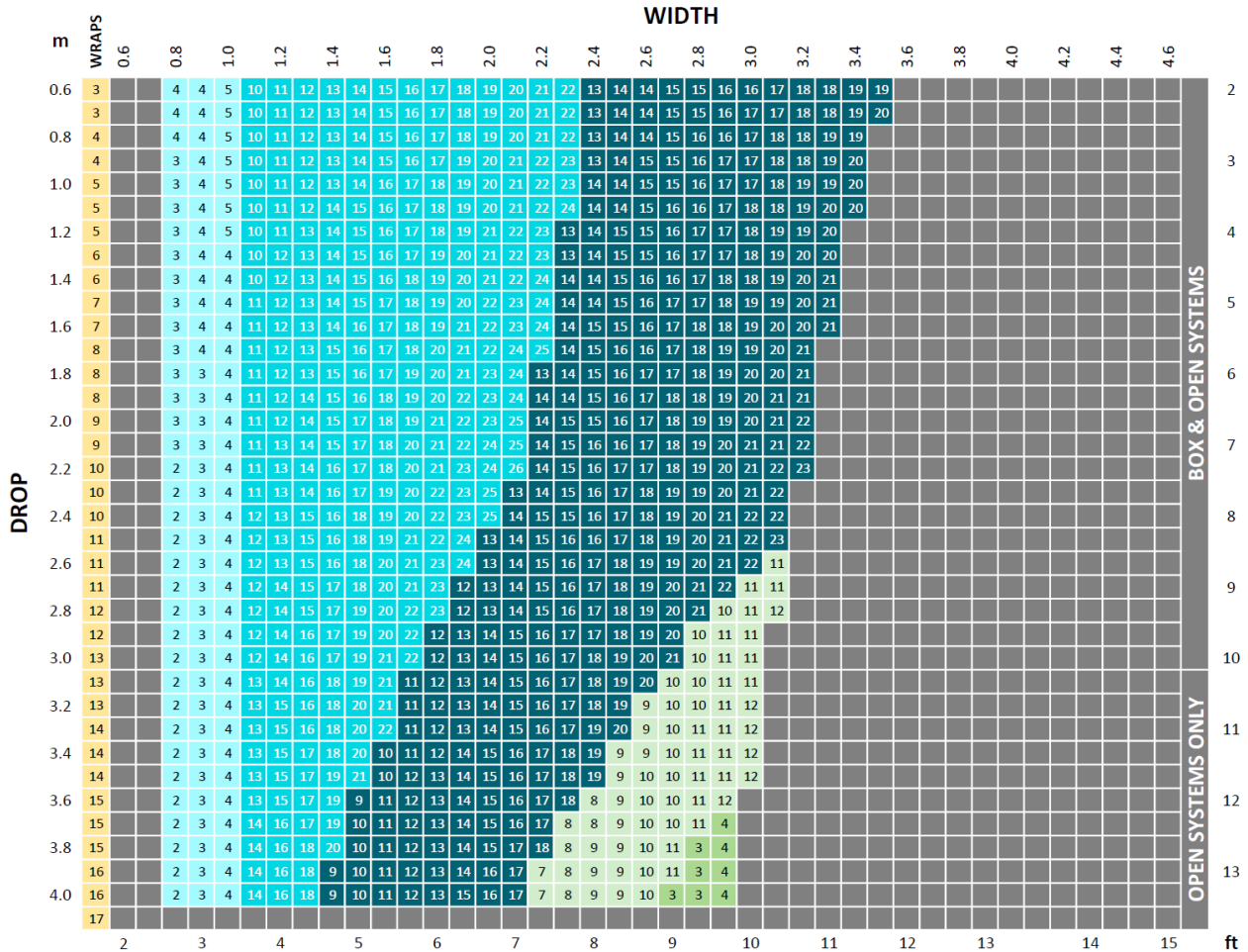

Parameters:

Tube: 63 STD Aluminium Tube

Fabric: 573gsm (19.36oz/yd²), 0.85mm Thick

Weight Bar: F56 HD External Weight Bar

LEGEND	DESCRIPTION	MAX SPRING ROTATIONS
	Outside Product Specifications	
	Short RE01 Spring	25
	Light RE01 Spring	40
	Standard RE01 Spring	38
	Heavy Duty RE01 Spring	31
	X-Heavy RE01 Spring	25

The above charts are indicative only and indicate the minimum number of pre-turns required. Due to variances in fabric weights, additional ballast weight and installations the optimum number of pre-turns will vary. Pre-turns can be adjusted during installation.

63mm TUBE [F56 Weight Bar + 12mm Round Ballast]

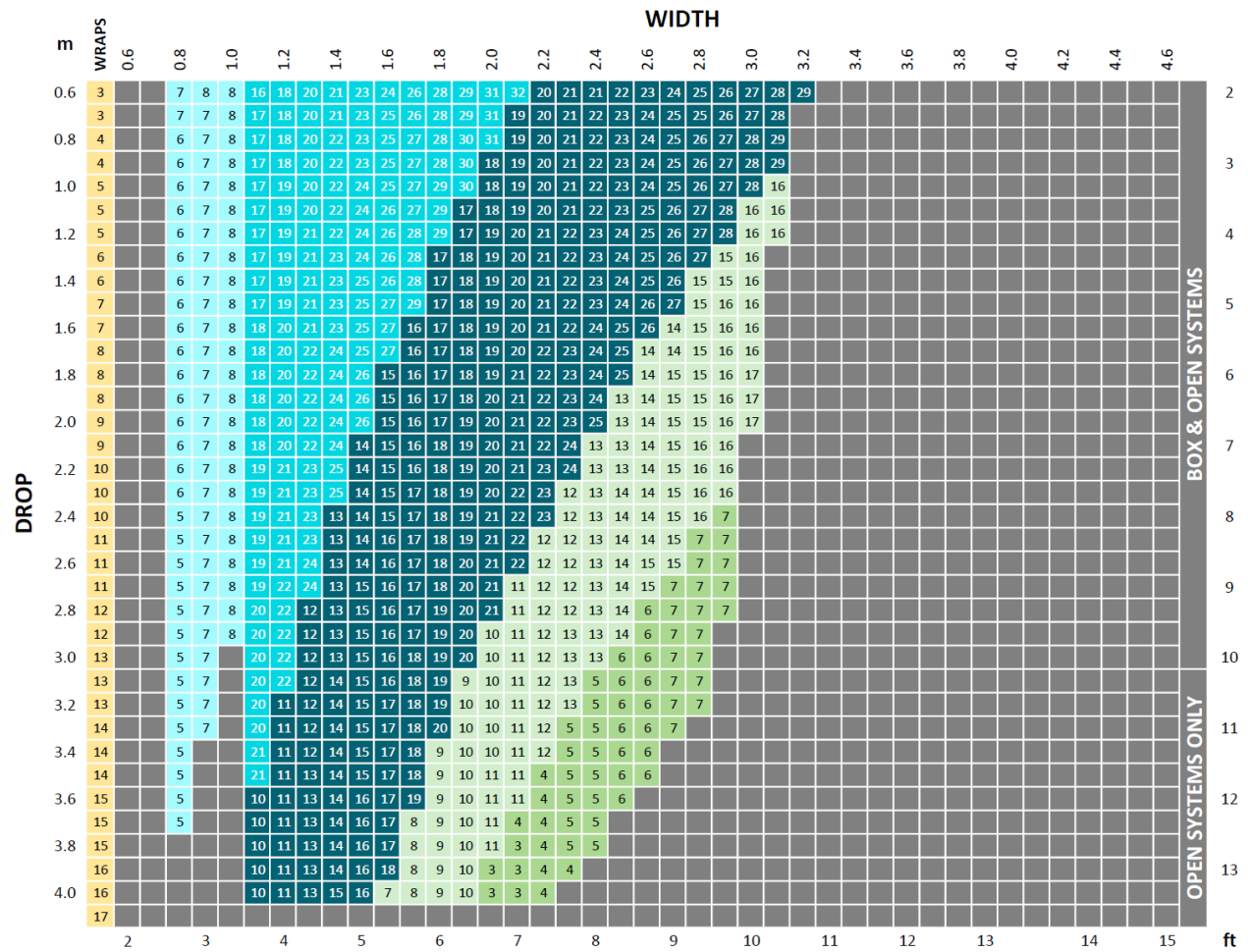

Parameters:

Tube: 63 STD Aluminium Tube

Fabric: 573gsm (19.36oz/yd²), 0.85mm Thick

Weight Bar: F56 HD External Weight Bar + 1x12mm Ballast

LEGEND	DESCRIPTION	MAX SPRING ROTATIONS
	Outside Product Specifications	
	Short RE01 Spring	25
	Light RE01 Spring	40
	Standard RE01 Spring	38
	Heavy Duty RE01 Spring	31
	X-Heavy RE01 Spring	25

The above charts are indicative only and indicate the minimum number of pre-turns required. Due to variances in fabric weights, additional ballast weight and installations the optimum number of pre-turns will vary. Pre-turns can be adjusted during installation.

78mm TUBE [F56 Weight Bar]

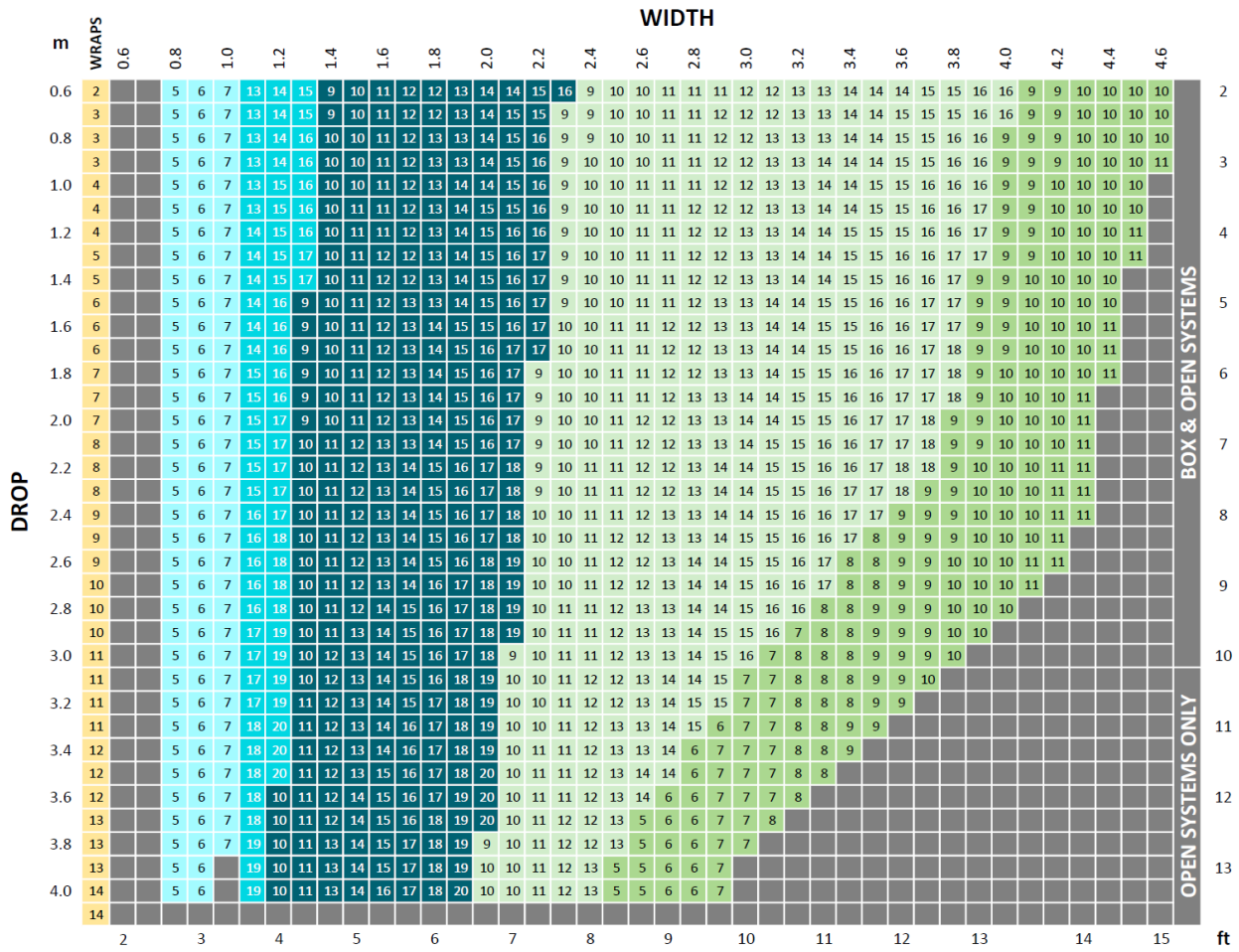

Parameters:

Tube: 78 HD Aluminium Tube (includes 78 AL STD & 78 STEEL)

Fabric: 573gsm (19.36oz/yd²), 0.85mm Thick

Weight Bar: F56 HD External Weight Bar

LEGEND	DESCRIPTION	MAX SPRING ROTATIONS
	Outside Product Specifications	
	Short RE01 Spring	25
	Light RE01 Spring	40
	Standard RE01 Spring	38
	Heavy Duty RE01 Spring	31
	X-Heavy RE01 Spring	25

The above charts are indicative only and indicate the minimum number of pre-turns required. Due to variances in fabric weights, additional ballast weight and installations the optimum number of pre-turns will vary. Pre-turns can be adjusted during installation. Refer to Section 2, Part F, Steps 7 – 10.

78mm TUBE [F56 Weight Bar + 12mm Round Ballast]

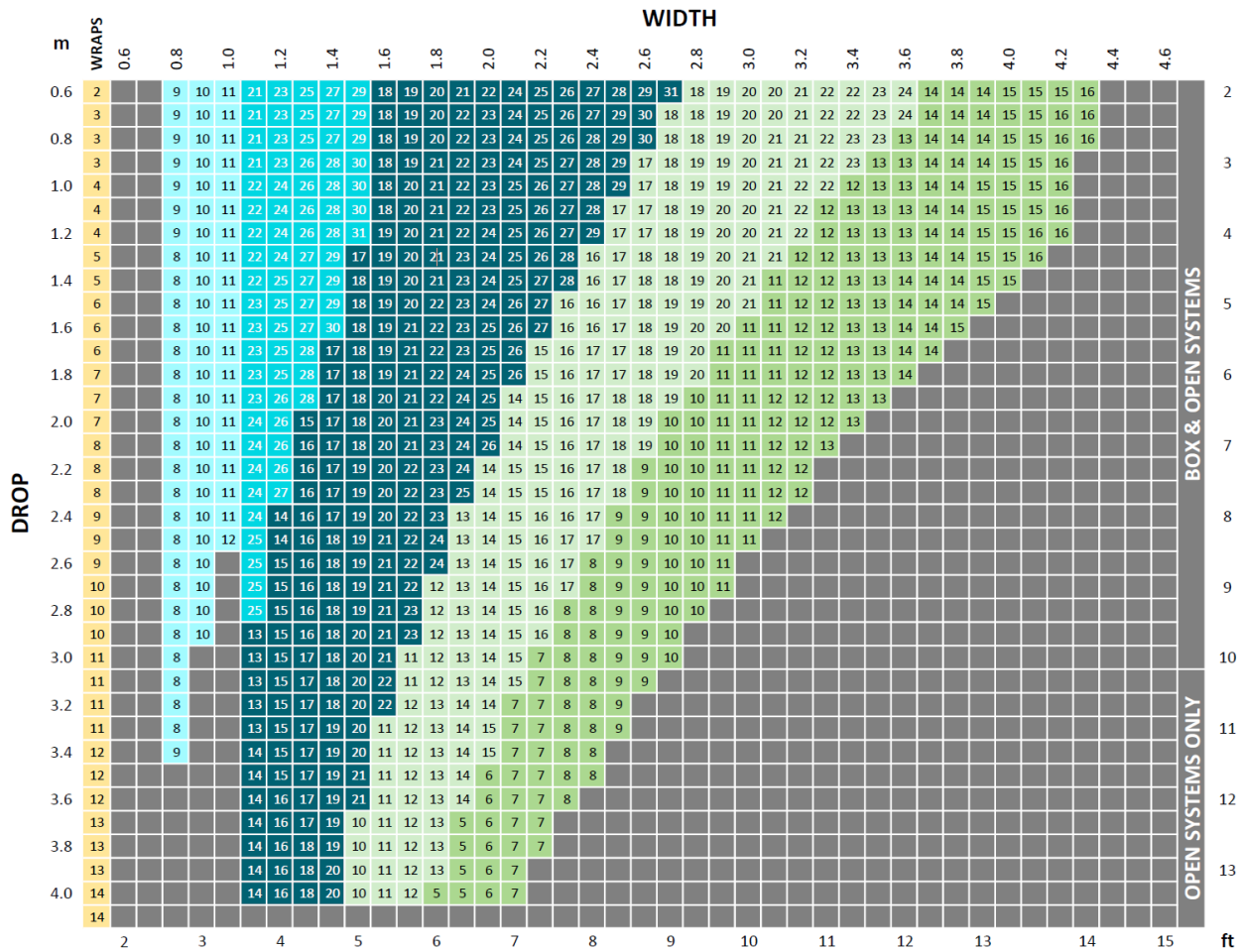

Parameters:

Tube: 78 HD Aluminium Tube (includes 78 AL STD & 78 STEEL)

Fabric: 573gsm (19.36oz/yd²), 0.85mm Thick

Weight Bar: F56 HD External Weight Bar + 1x12mm Ballast

LEGEND	DESCRIPTION	MAX SPRING ROTATIONS
	Outside Product Specifications	
	Short RE01 Spring	25
	Light RE01 Spring	40
	Standard RE01 Spring	38
	Heavy Duty RE01 Spring	31
	X-Heavy RE01 Spring	25

The above charts are indicative only and indicate the minimum number of pre-turns required. Due to variances in fabric weights, additional ballast weight and installations the optimum number of pre-turns will vary. Pre-turns can be adjusted during installation. Refer to Section 2, Part F, Steps 7 – 10.

STEP 2 – LOCK SPRING HEAD AT SPRING END

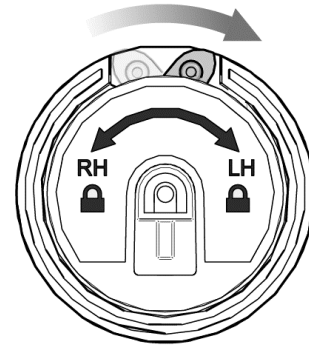
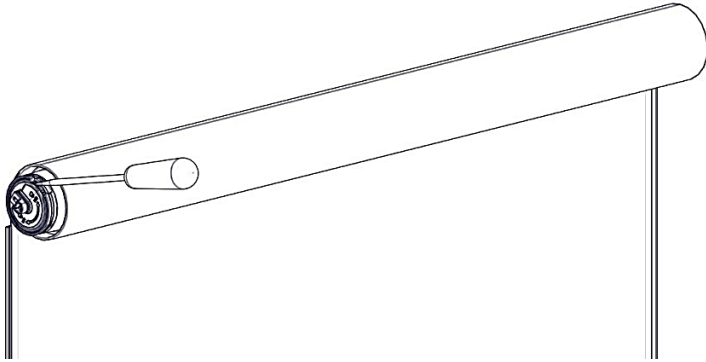

LEFT HAND LOCKED

STEP 3 – ENGAGE SPANNER ONTO PRE-TENSION SPINDLE

Slide Down to Engage

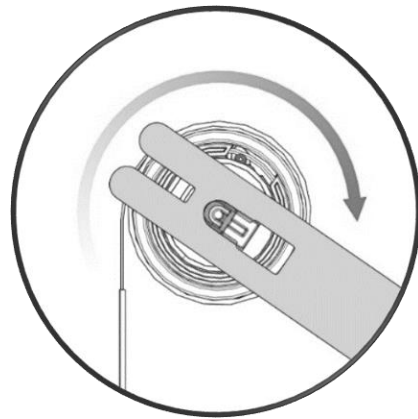
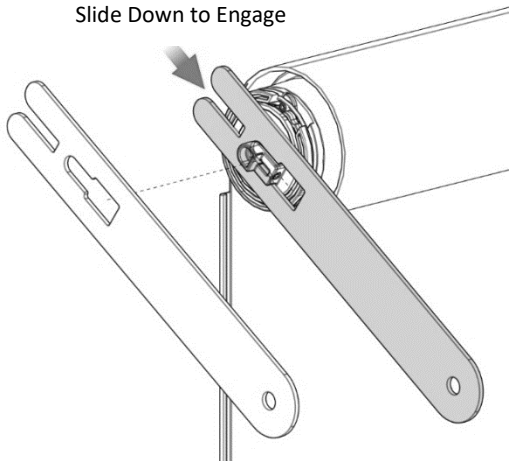

STEP 4 – ROTATE SPINDLE AS PER DIRECTION INDICATED ON LABEL

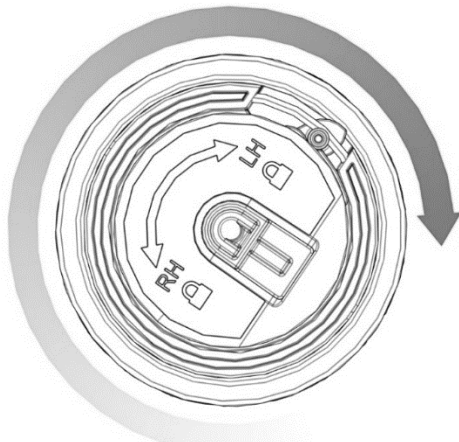

LEFT HAND
Pre-Tension Clockwise

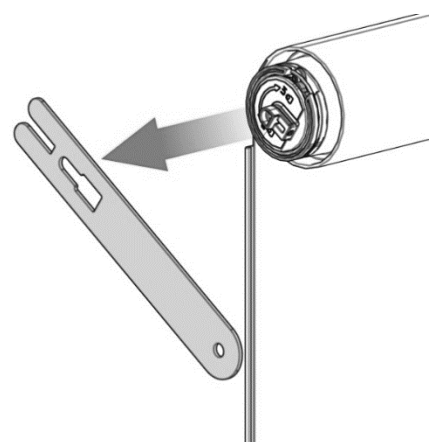

Remove Spanner

Pre-turn spring for number of times indicated in Section 2, Part B.
A click will be heard for each turn

PART C – BOX INSTALLATION

STEP 1 – INSTALL BOX TO WALL/CEILING

FACE FIX

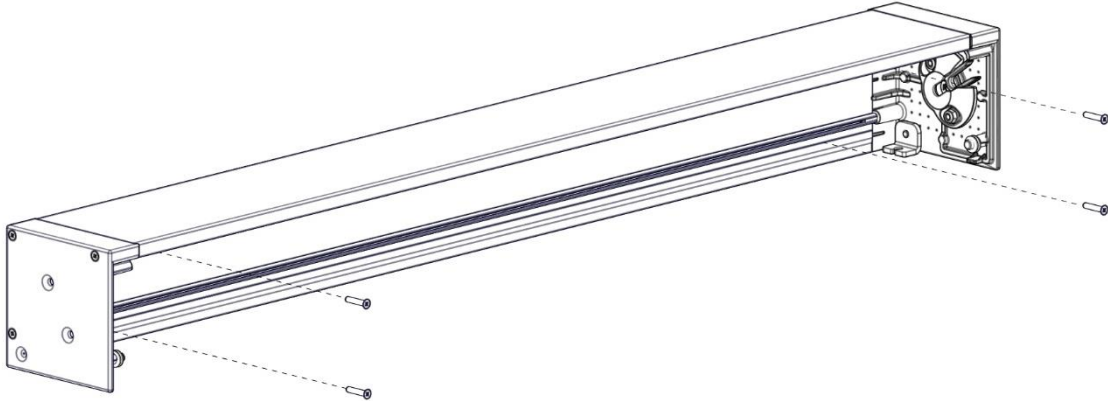

Note: Use appropriate fixings to suit application
Ensure Box is Aligned and Level

TOP FIX

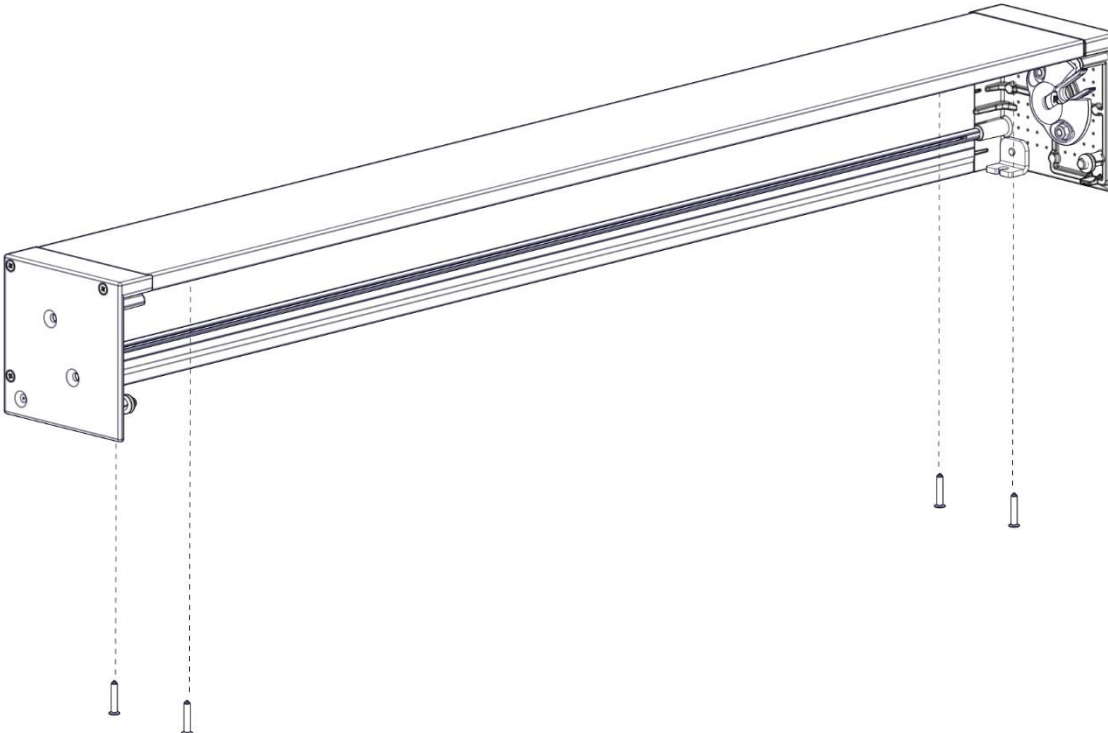

Note: Use appropriate fixings to suit application
Ensure Box is Aligned and Level

SIDE FIX

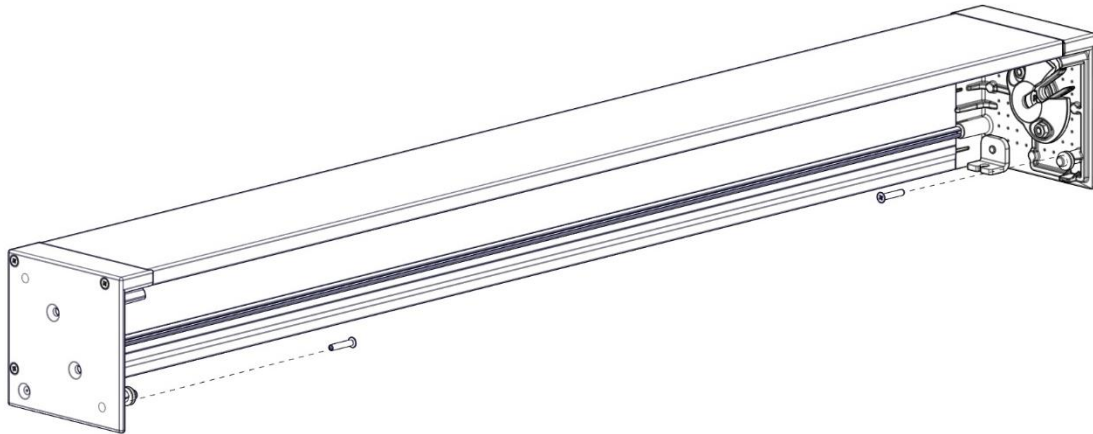

Note: Use appropriate fixings to suit application
Ensure Box is Aligned and Level

PART D – COVER INSTALLATION

STEP 1 – INSTALL END PLATES TO WALL/CEILING USING APPROPRIATE FIXINGS TO SUIT APPLICATION

FACE FIX

Fascia Bracket (RE03-0101-xxx000)
may be required as a centre support
for larger spans

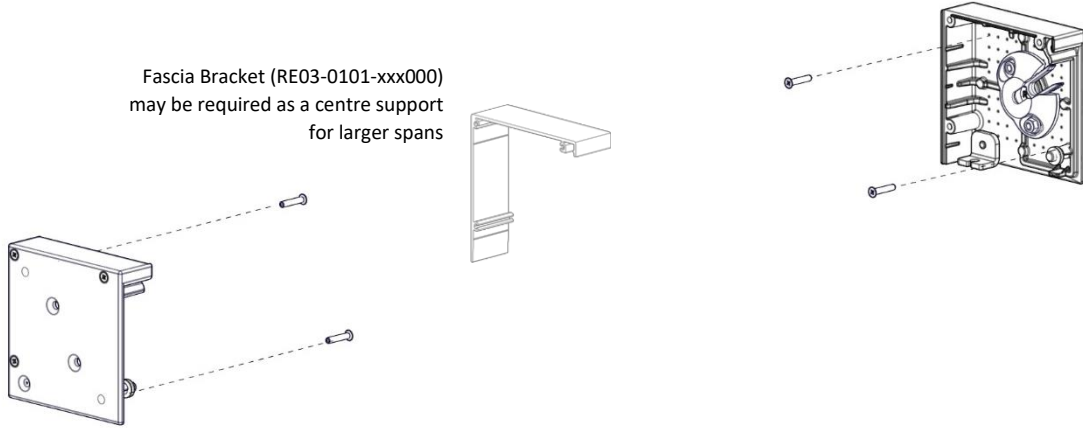

Note: Use appropriate fixings to suit application
Ensure End Plates are aligned and level
Measure brackets end to end to confirm measurement is correct

TOP FIX

Fascia Bracket (RE03-0101-xxx000)
may be required as a centre support
for larger spans

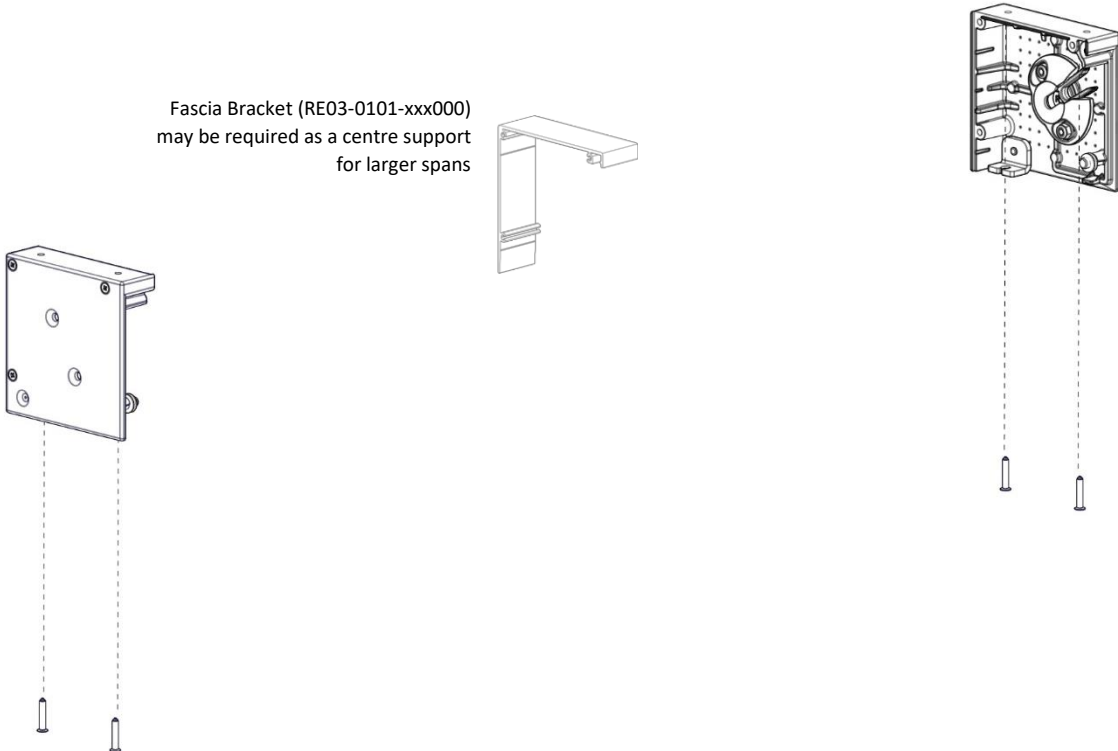

Note: Use appropriate fixings to suit application
Ensure End Plates are aligned and level
Measure brackets end to end to confirm measurement is correct

SIDE FIX

Fascia Bracket (RE03-0101-xxx000)
may be required as a centre support
for larger spans. If possible.

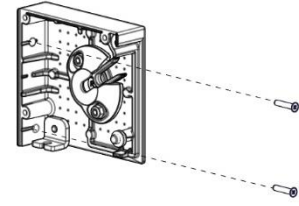
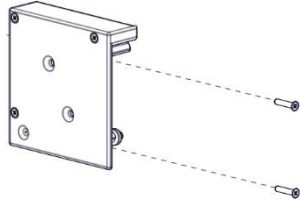

Note: Use appropriate fixings to suit application
Ensure End Plates are aligned and level
Measure brackets end to end to confirm measurement is correct

PART E – OPEN BRACKET INSTALLATION

FACE FIX

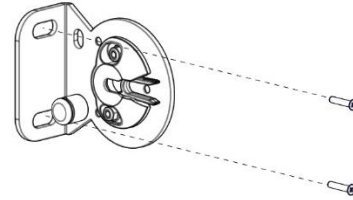
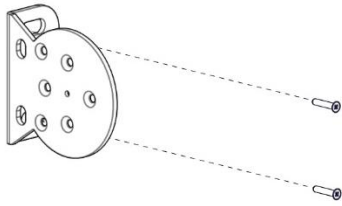

Note: Use appropriate fixings to suit application
Ensure brackets are aligned and level
Measure brackets end to end to confirm measurement is correct

TOP FIX

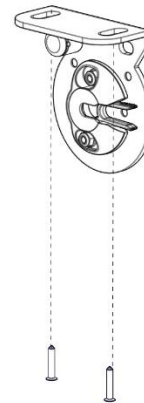
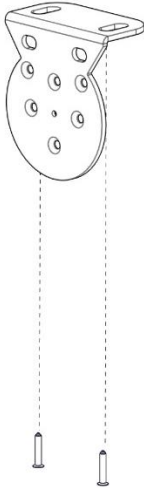

Note: Use appropriate fixings to suit application
Ensure brackets are aligned and level
Measure brackets end to end to confirm measurement is correct

SIDE FIX

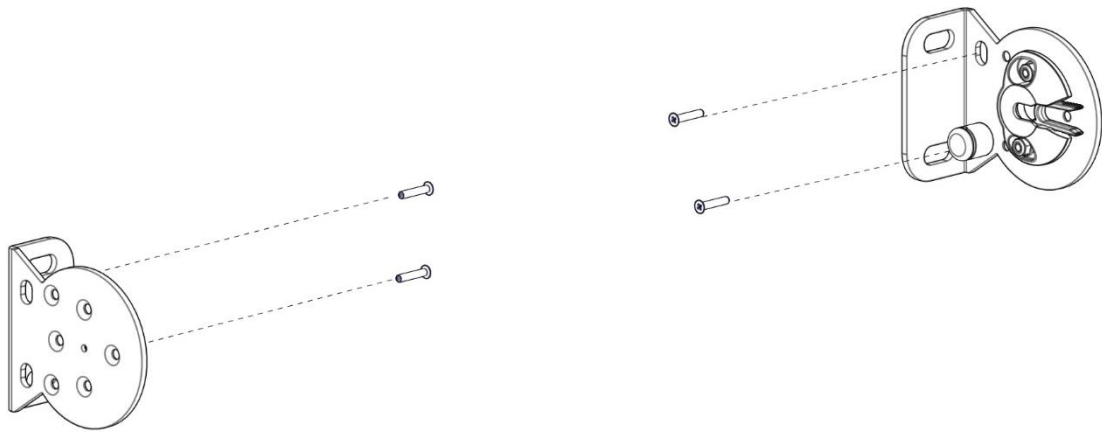

Note: Use appropriate fixings to suit application
Ensure brackets are aligned and level
Measure brackets end to end to confirm measurement is correct

PART F – BLIND INSTALLATION

STEP 1 – MARK & SECURE WIRE GUIDE FIXINGS AND TRIM WIRE TO SUIT

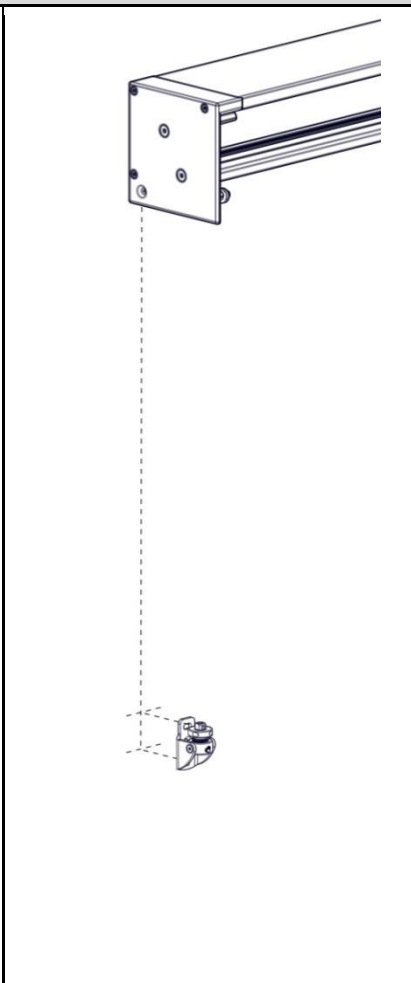
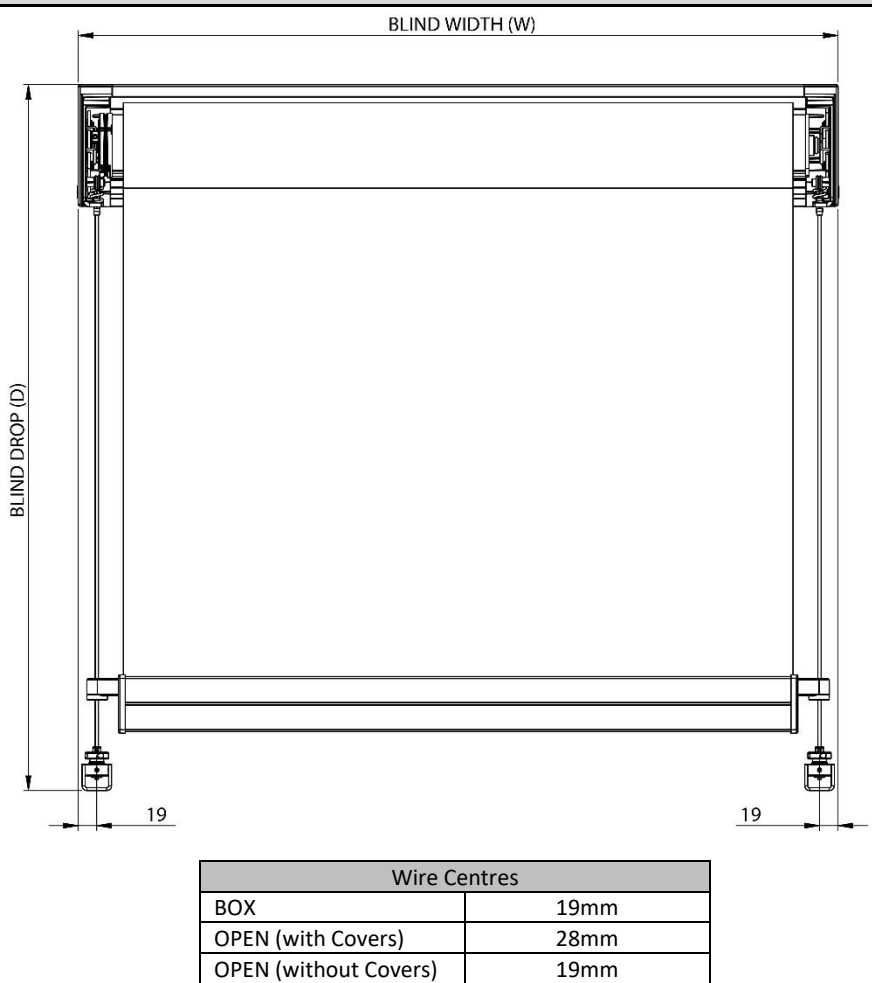

NOTE: Cut wire to assist installation (ensure wire is not cut too short, excess can be trimmed later)

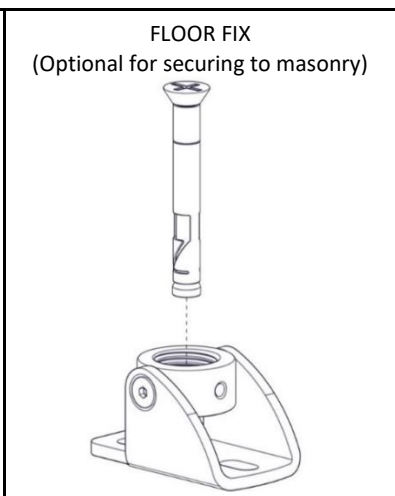
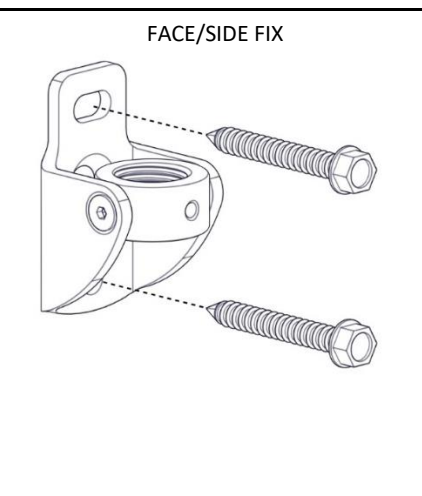
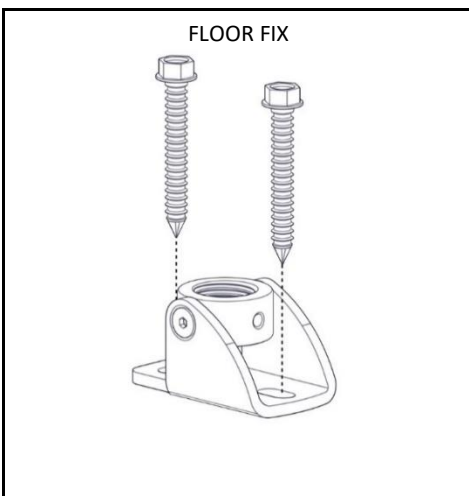

NOTE: Ensure fasteners suit substrate application
Max fastener size #10, Max Dynabolt Size: M6

STEP 2 – INSERT SPRING ONTO WIRE (OPTION 1)

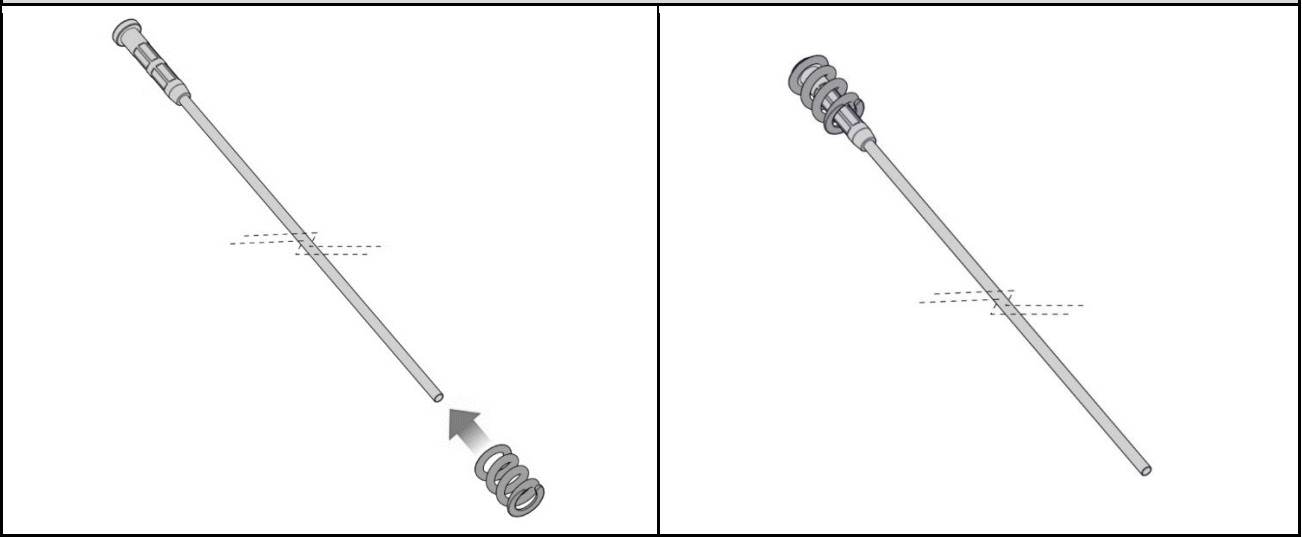

STEP 3 – ATTACH WIRE AND SPRING TO BRACKET

OPTION 1 – HOOK TERMINAL

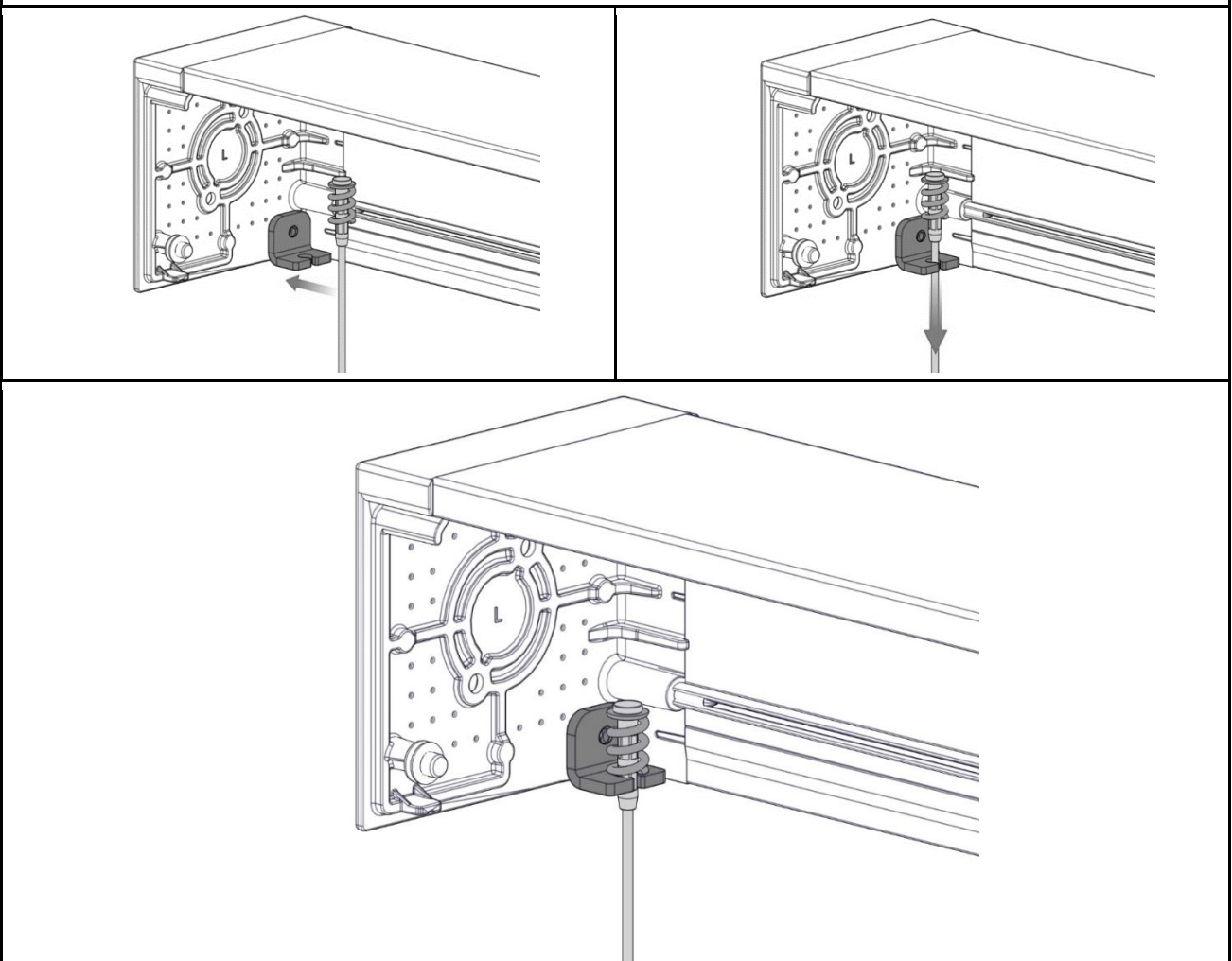

NOTE: Tube hardware not shown for clarity of wire installation

OPTION 2 – CLAMP TERMINAL

Insert wire between two terminal pieces and tighten screw to fix wire

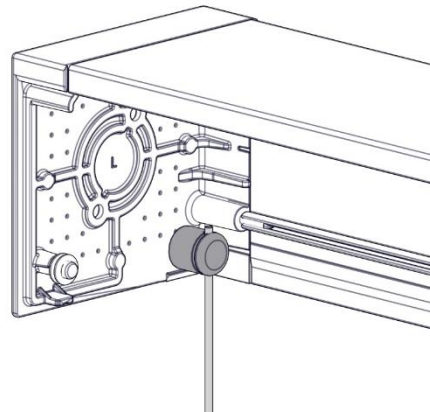
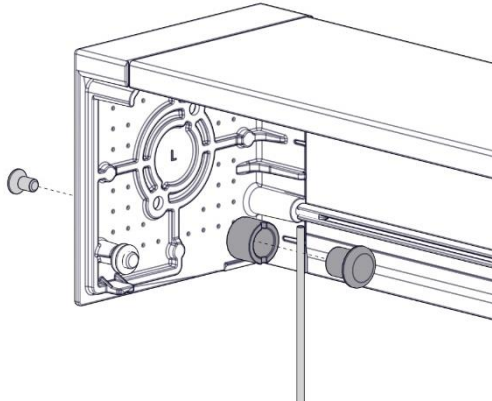

Note:

- Dome Stud Terminal must be removed prior to installation
- Compression spring above cannot be used with Clamp Terminal

STEP 4 – INSERT BLIND INTO BOX

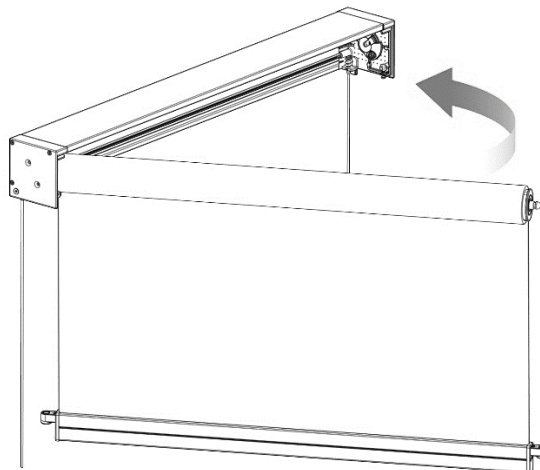

NOTE:

- Insert control end first
- Ensure blind is secure

STEP 5 – INSERT WIRE THROUGH WEIGHT BAR END CAP FLOATS

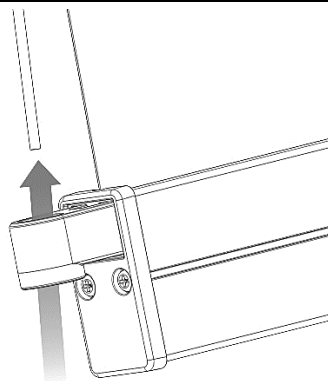

STEP 6 – INSERT CLIP ONTO IDLER ADAPTER

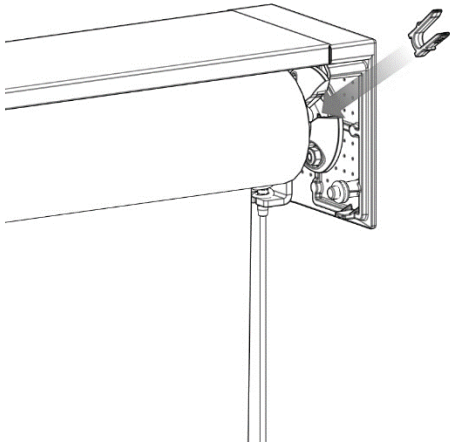

Ensure it is clipped in securely

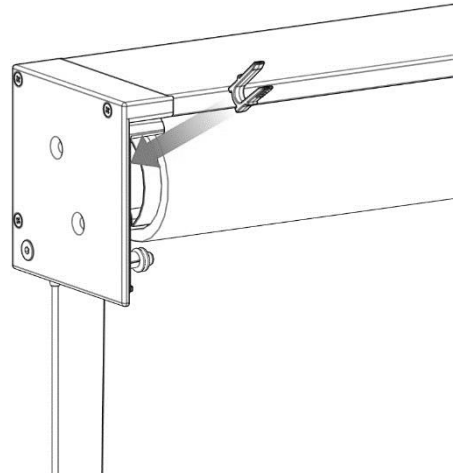

SPRING ONLY: Insert Clip at spring end

STEP 7 – UNLOCK PRE-TENSION HEAD AT SPRING END (FOR SPRING ONLY)

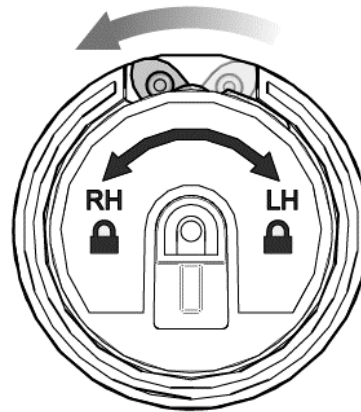
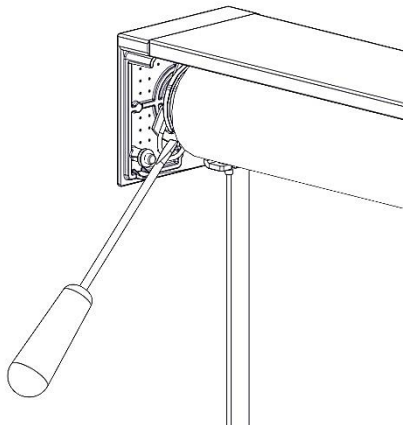

STEP 8 – FEED THROUGH MOTOR CABLE (FOR MOTOR ONLY)

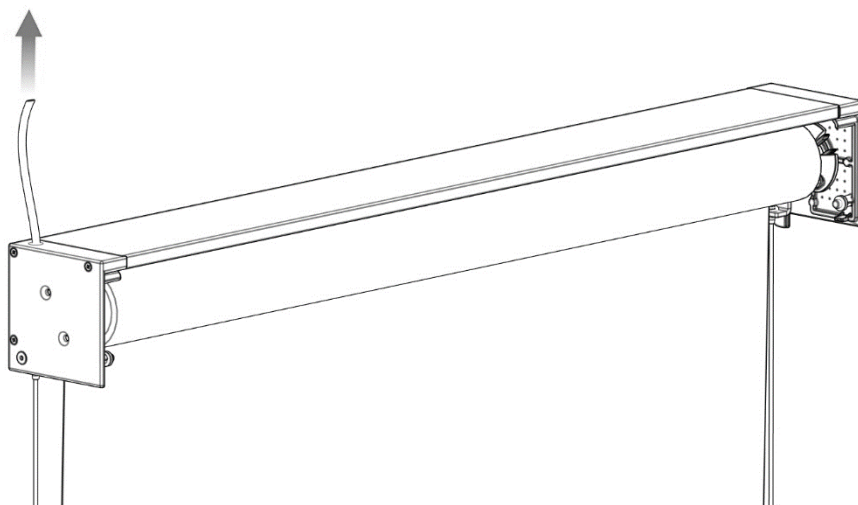

STEP 9 – RUN BLIND DOWN + CENTRE

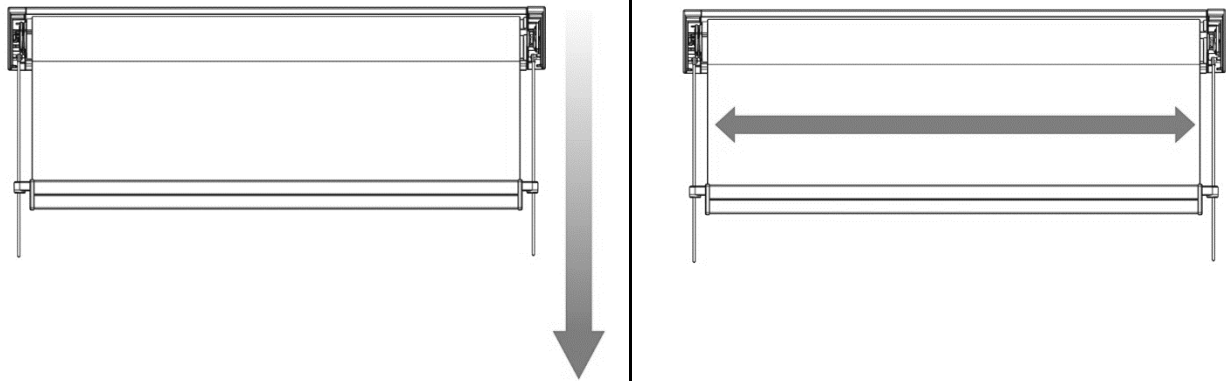

STEP 10 – TEST BLIND OPERATION

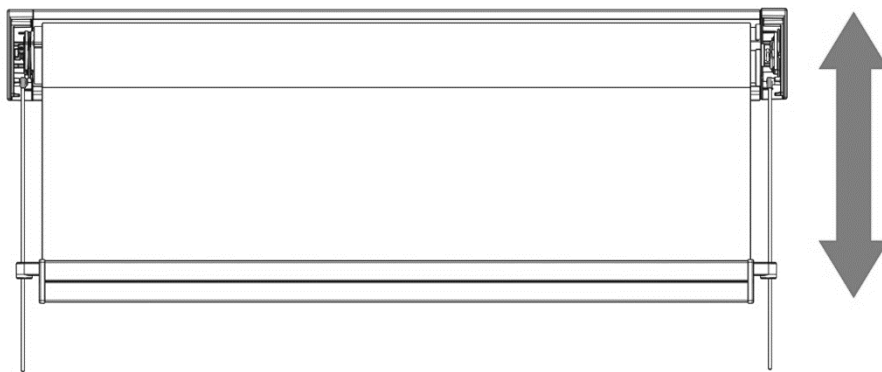

For spring operation, blind should creep up slowly when pulled down.
If blind does not creep up, add more pre-turns. Refer steps 7 - 10
For motor operation, ensure wiring is correct and motor is operating correctly.
For gear operation, ensure operation is smooth.
Once blind is operating correctly, proceed to SECTION 2 / Part G.

STEP 8 – ENSURE SPRING IS LOCKED BY LIFTING WEIGHT BAR UNTILL FABRIC BUNCHES UP

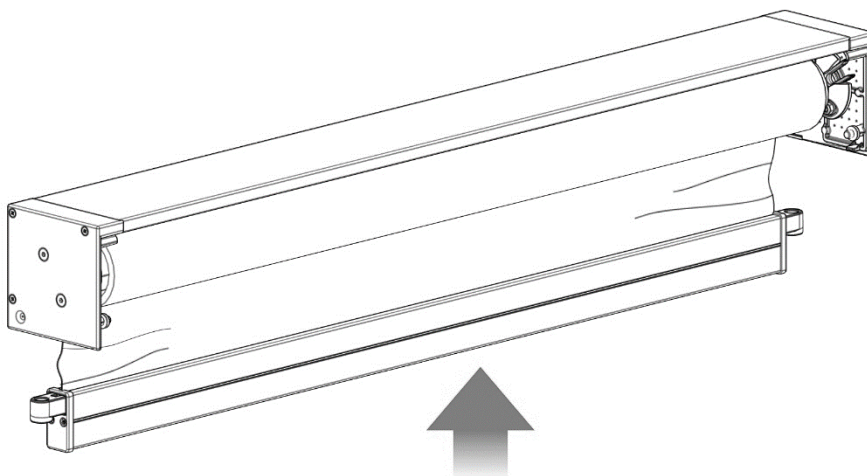

STEP 11 – TO ADJUST PRE-TURNS LOCK PRE-TENSION HEAD AT SPRING END (FOR SPRING ONLY)

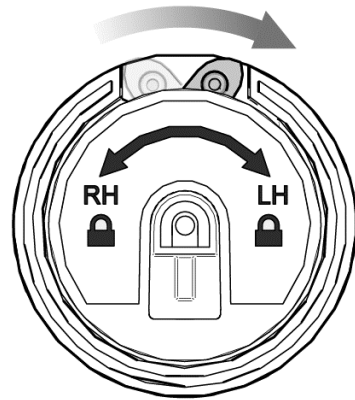
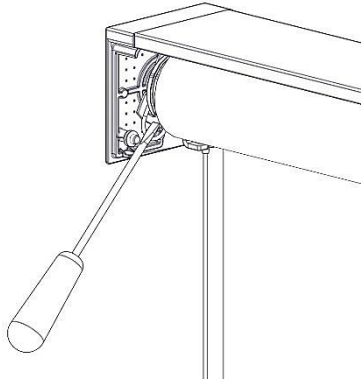

STEP 12 – DISENGAGE PRE-TENSION IDLER AT SPRING END FROM ADAPTER (FOR SPRING ONLY)

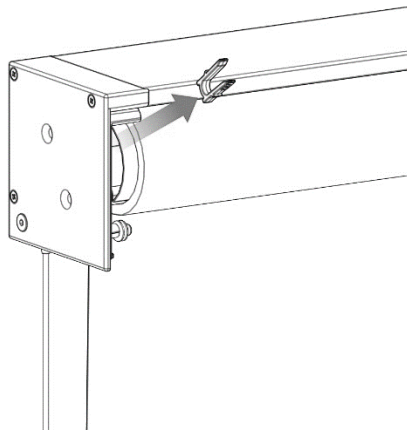

STEP 13 – ADD ADDITIONAL PRE-TURNS REQUIRED (FOR SPRING ONLY)

Add extra number of pre-tensions required.
Refer to Section 2, Part B, Steps 3-4 for details.
Note: Gradually increase the number of pre-turns required.

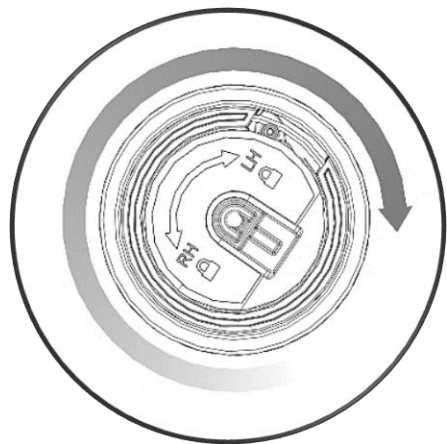
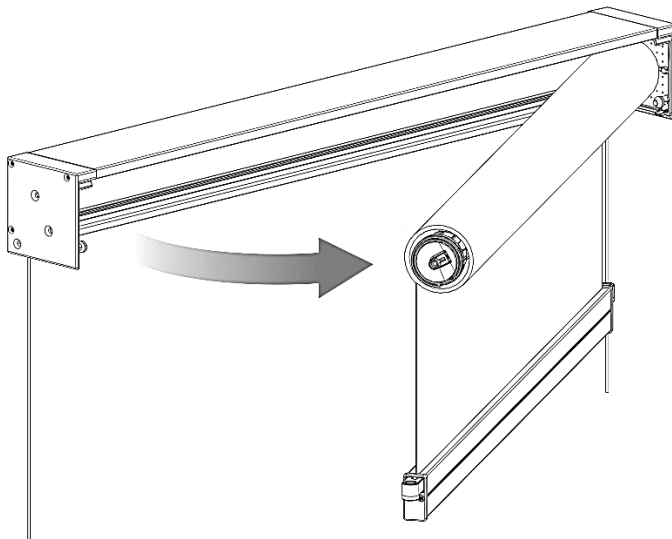

STEP 14 – RE-INSTALL AND TEST BLIND (FOR SPRING ONLY)

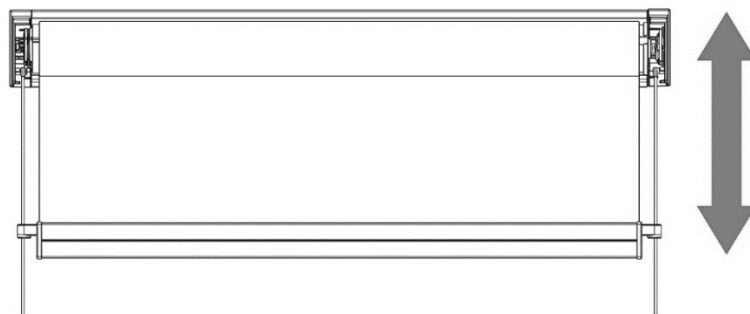

If too many pre-turns are added, the blind will automatically raise when installed.
Repeat steps 10-13 until blind is operating as required.

PART G – TENSION GUIDELINES

STEP 1 – SLIDE LOCK ONTO BOTTOM OF WIRE, POSITION HIGH TO KEEP OUT OF THE WAY AND TEMPORARILY CLAMP IN PLACE

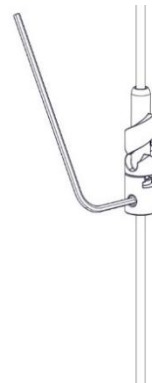
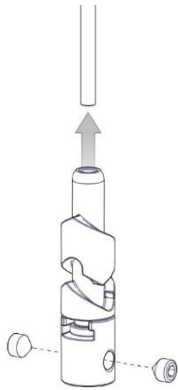

NOTE:

- Use 2.5mm Allen Key
- Ensure locks are below Weight Bar

STEP 2 – SLIDE ADJUSTING SLEEVE THEN WIRE TERMINAL ONTO WIRE AND TIGHTEN UP OUT OF THE WAY



NOTE: Use 2mm Allen Key

STEP 3 – FEED WIRE THROUGH SWIVEL BRACKET COLLAR

FLOOR FIX



FACE/SIDE FIX



STEP 4 – PULL WIRE STRAIGHT AND ALIGN TERMINAL FLANGE WITH M4 GRUB SCREW, CLAMP TO WIRE

FLOOR FIX

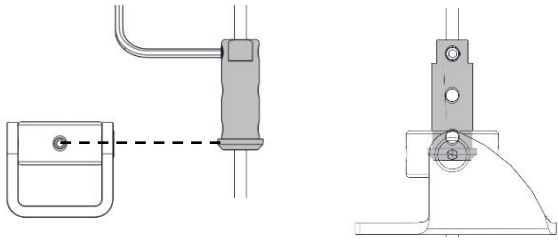

FACE/SIDE FIX

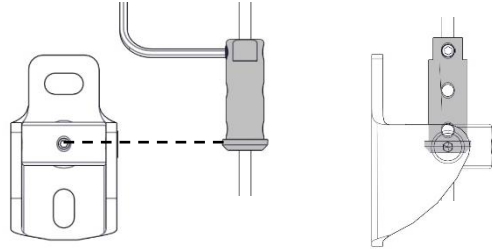

STEP 5 – TIGHTEN REMAINING GRUB SCREWS ON WIRE (TIGHTEN 3X GRUB SCREWS PER WIRE)

FLOOR FIX

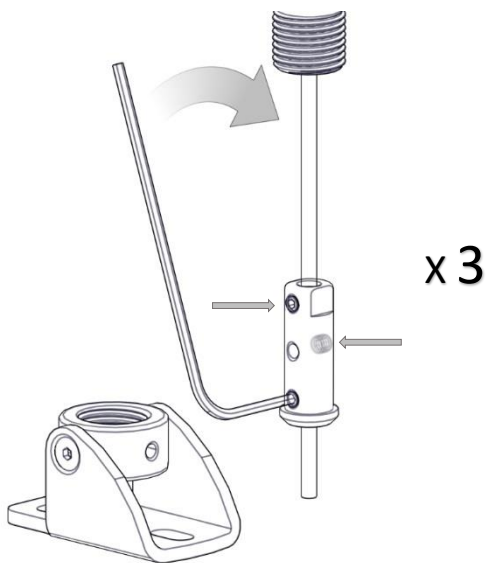

NOTE: Use 2mm Allen Key

FACE/SIDE FIX

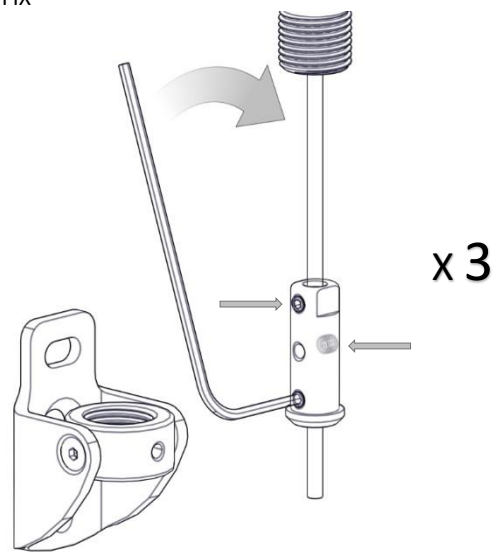

NOTE: Use 2mm Allen Key

STEP 6 – LOWER ADJUSTING SLEEVE INTO COLLAR TO TENSION WIRE

FLOOR FIX

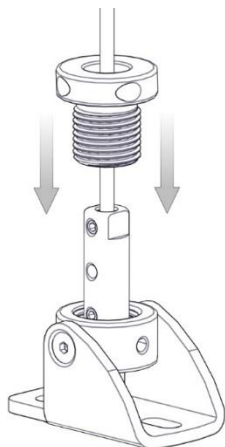

FACE/SIDE FIX

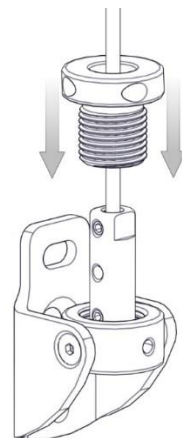

STEP 7 – SCREW IN ADJUSTING SLEEVE UNTIL WIRE BEGINS TO TENSION

FLOOR FIX

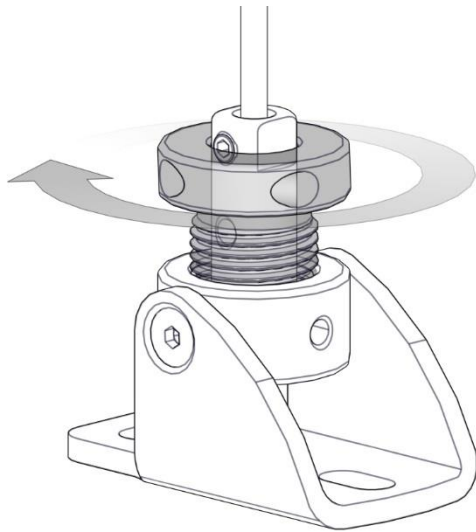

FACE/SIDE FIX

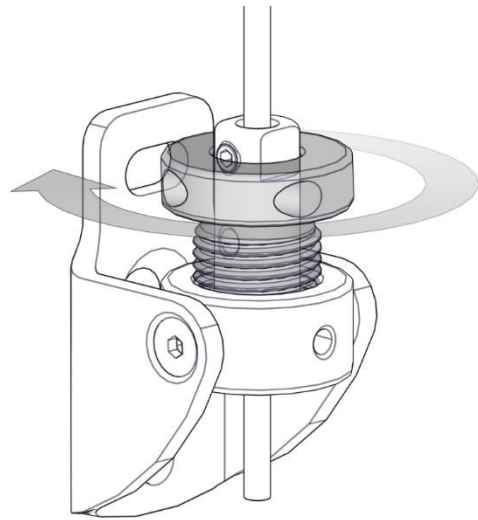

STEP 8 – TO APPLY MIN REQUIRED TENSION, TIGHTEN WITH 5X TURNS USING ALLEN KEY

FLOOR FIX

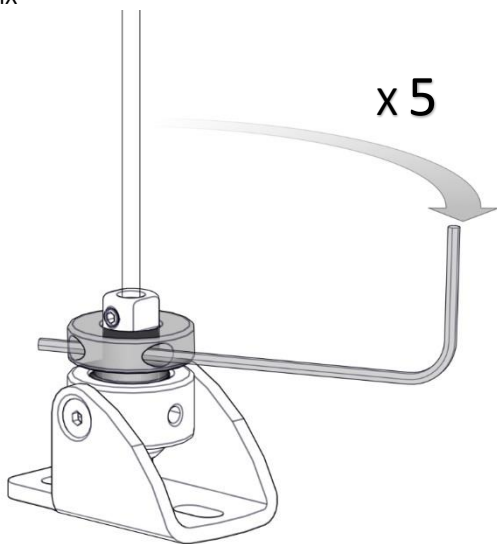

FACE/SIDE FIX

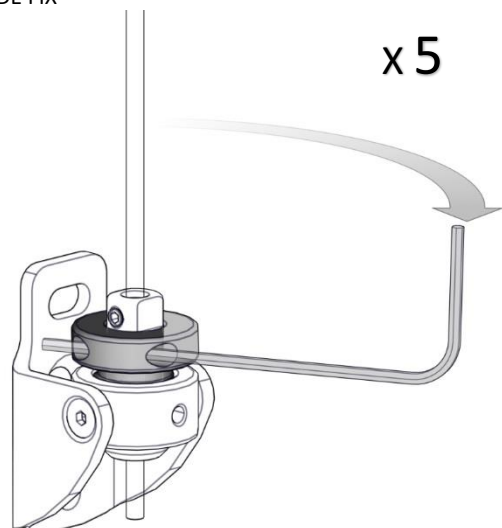

NOTE: Use 4mm Allen Key

STEP 9 – ONCE TENSIONED SCREW IN GRUB SCREW TO PREVENT LOSING TENSION

FLOOR FIX

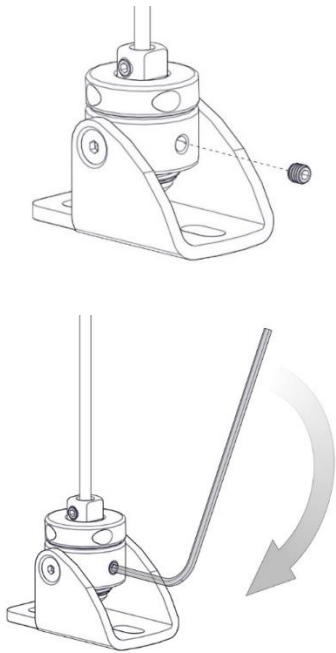

NOTE: Use 2mm Allen Key

FACE/SIDE FIX

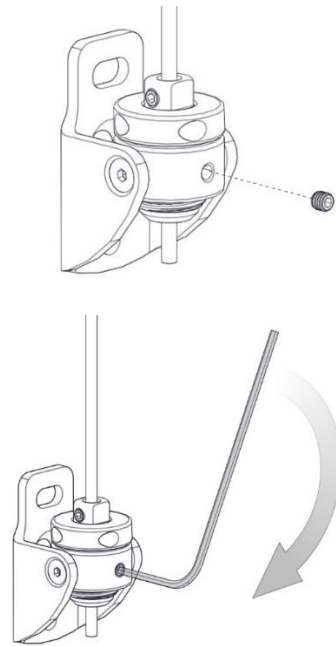

STEP 10 – RELEASE LOCK AND SLIDE UP INTO WEIGHT BAR END CAP (LATCH)

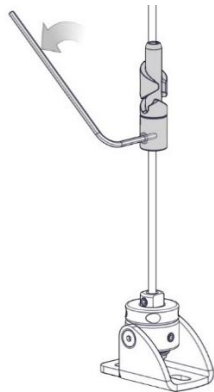

NOTE: Use 2mm Allen Key

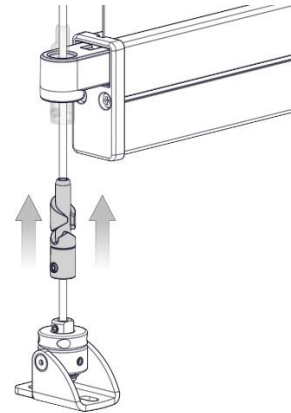

Repeat for other side

STEP 11 – LOCKS SHOULD NOW MOVE WITH WEIGHT BAR

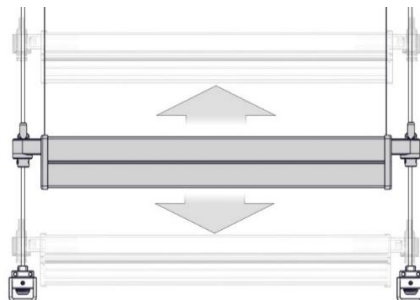

STEP 12 – MOVE WEIGHT BAR/LOCK TO LOWEST DESIRED LEVEL

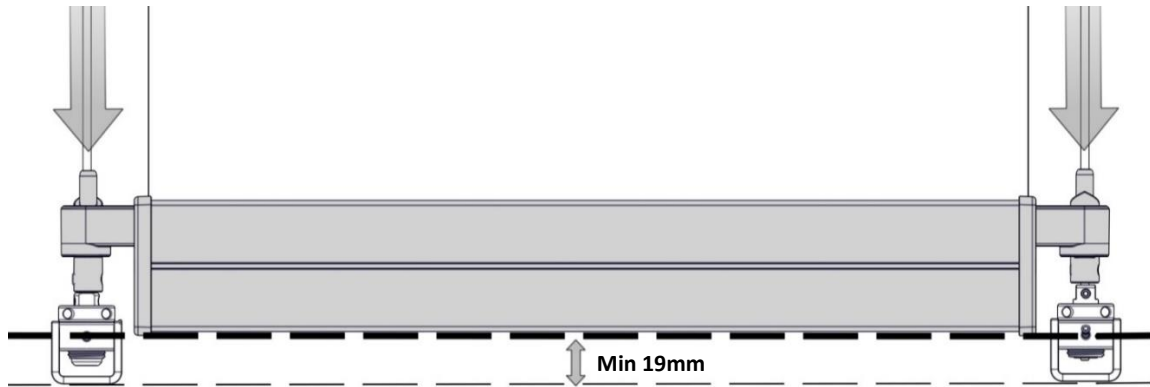

Choose lowest position for weight bar.
Min Ground Distance = 19mm approx.

STEP 13 – FIX LOCK IN PLACE WITH GRUB SCREWS (2 EACH SIDE)

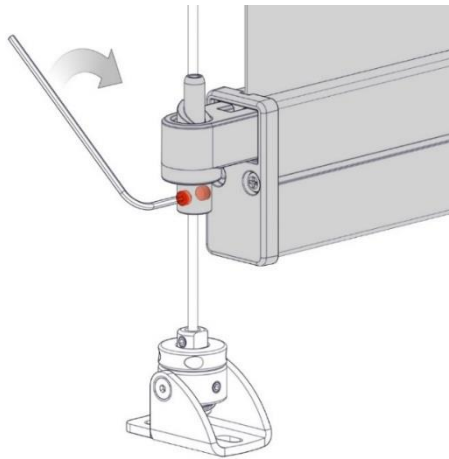

NOTE: Tighten set of 2 grub screws per wire

STEP 14 – TEST BLINDS WITH LOCKS

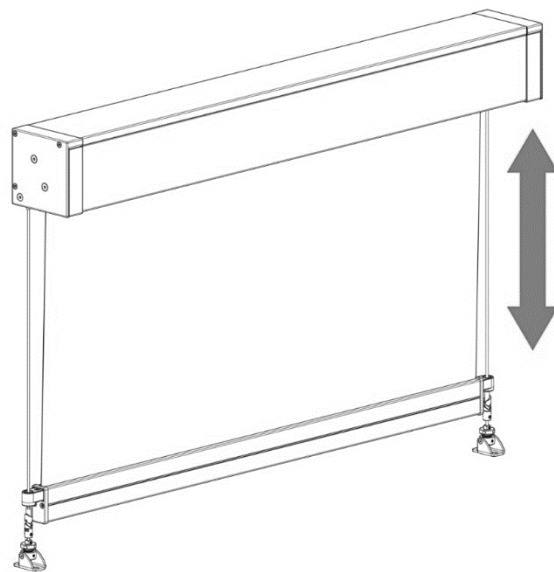

NOTE: Adjust lock heights if required (Refer to Section 2, Part G, Steps 11 to 14)

PART H – INSERT BOX / COVER

STEP 1 – SWING BOX COVER INTO BOX TOP AND CLIP INTO PLACE

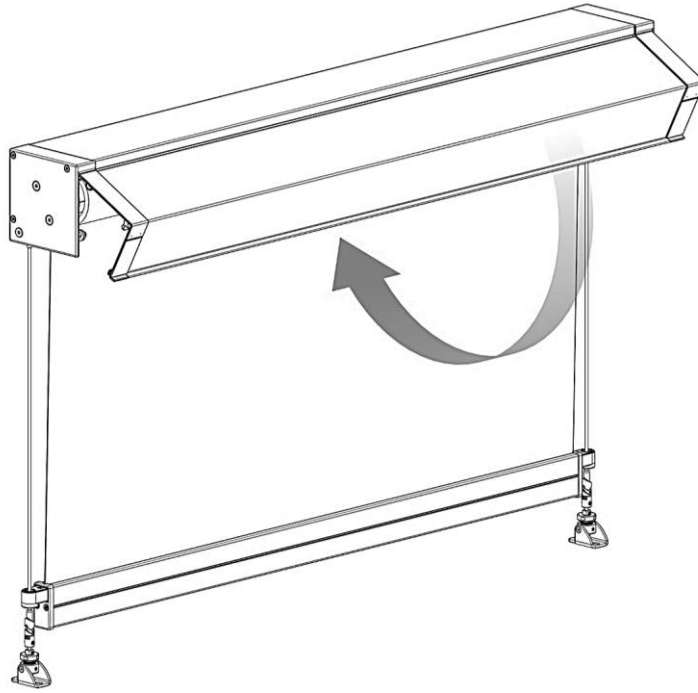

STEP 2 – SECURE COVER AT BOTH ENDS

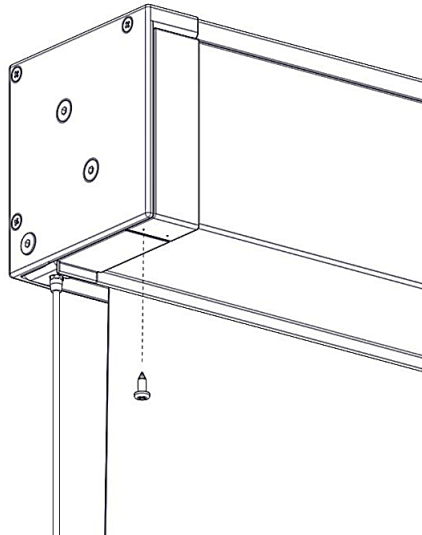

Note: It is recommended that the Box Cover be fixed to ensure it is not accidentally dislodged

INSTALLED WIRE GUIDE

BOX

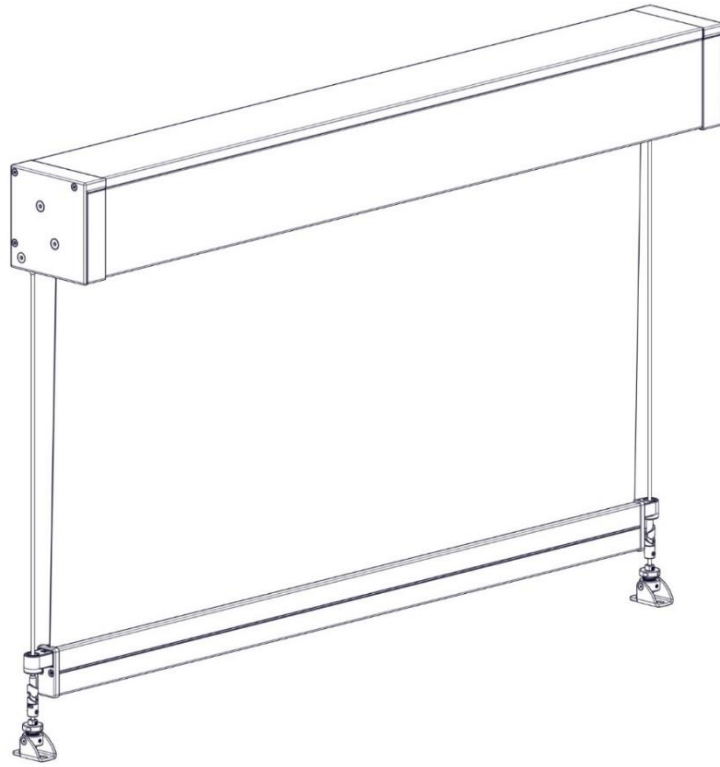

OPEN

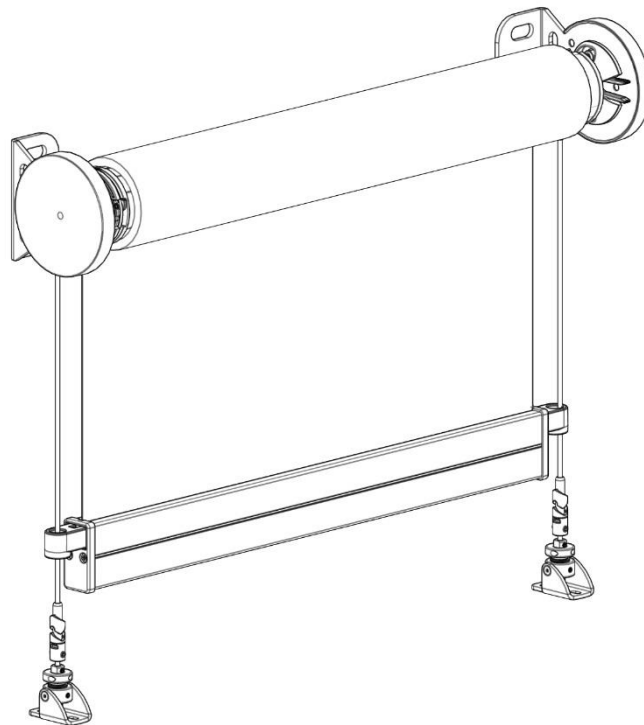

SECTION 3 – TROUBLESHOOTING

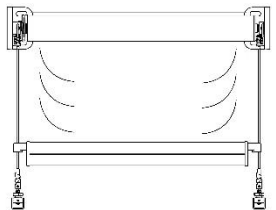
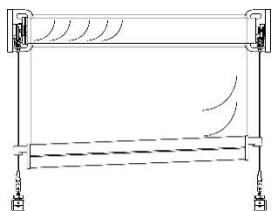
NO.	PROBLEM	CAUSE	SOLUTION
1	<p>Ripples along sides of fabric</p> 	Blind rolled up for an extended period of time.	This occurrence is inherent to roller systems and is more prevalent in some fabrics. Leave blind down for 1 – 4 hours; most ripples should disappear.
		Not enough weight in weight bar.	Refer to Product Specs. Add ballast.
		Installation is not square.	Check blind roll is installed level.
		Fabric permanently damaged due to inadequate handling during assembly, transportation, installation or use.	Replace fabric and ensure it is handled with care.
2	Blind does not fully open / jams	Position of wire guides at base is incorrect.	Check if wire guide fixing at floor/base are positioned in line with the Top Terminal. If fixing is too far inwards of the terminal then reposition. Refer to Part C, Step 1 of this document for wire guide positioning details.
		Incorrect motor stop limits used.	Refer to motor instructions to reset stop limits.
3	<p>Uneven weight bar</p> 	Blind roll is not level, thus weight bar appears uneven.	Ensure blind is installed level.
		Blind has been operated in excessive wind conditions.	Check blind roll when the blind is fully raised. If ripples are evident on roll, open blind fully (without the presence of wind) to allow the blind to track down evenly. Raise and lower blind a number of times to check operation.
		Fabric is not installed straight.	Ensure fabric is assembled straight onto tube and weight bar.
4	Locks go out of sync	Locks are not level	Lower blind until fabric is slack then lift one side so that the lock disengages
		Uneven Weight Bar (see above)	
		Obstruction preventing weight bar lowering through lock	Remove obstruction to allow weight bar to reach its lowest point.