







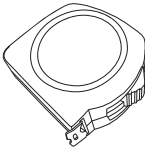
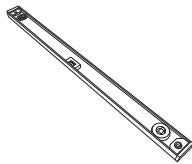
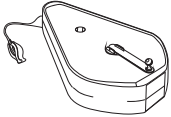

## BEFORE YOU START

Carefully read these instructions and refer to them constantly during each stage of construction. If you do not have all the necessary tools or information, contact Stratco for advice. Before starting, lay out all components and check them against the delivery docket. The parts description identifies each key part. Double check all dimensions, levels and bolting locations before cutting, screwing or bolting structural members.

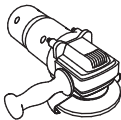
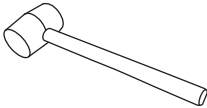
## TOOLS REQUIRED

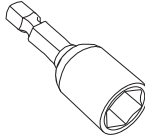
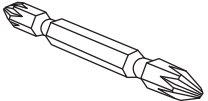
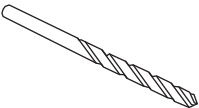
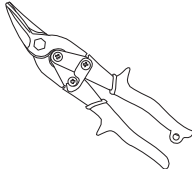
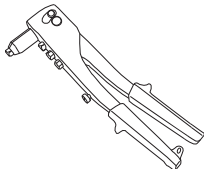
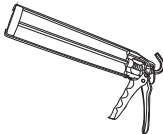
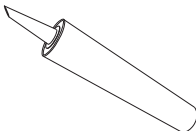
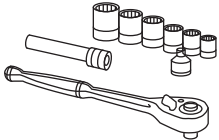
|  |  |  |   |   |  |
|--|--|--|---|---|--|
| Safety Glasses<br>        | Safety Gloves<br> | Ladders<br>       | Measuring Tape<br> | Spirit Level<br>     | String Line<br>           |
| Marker<br>                | Angle Grinder<br> | Rubber Mallet<br> | Cordless Drill<br> | Hex-Head Adaptor<br> | Phillips Head Adaptor<br> |
| Drill Bits (Assorted)<br> | Tin-Snips<br>     | Rivet Gun<br>     | Caulking Gun<br>   | Silicone<br>         | Socket Set<br>            |

# HANDI-HILANDER SHED

INSTALLATION GUIDE: HANDI-HILANDER GARDEN SHED  
[TYPE 1 - SIDE DOOR]

# HANDI-HILANDER GARDEN SHED INSTALLATION GUIDE

## COMPONENTS

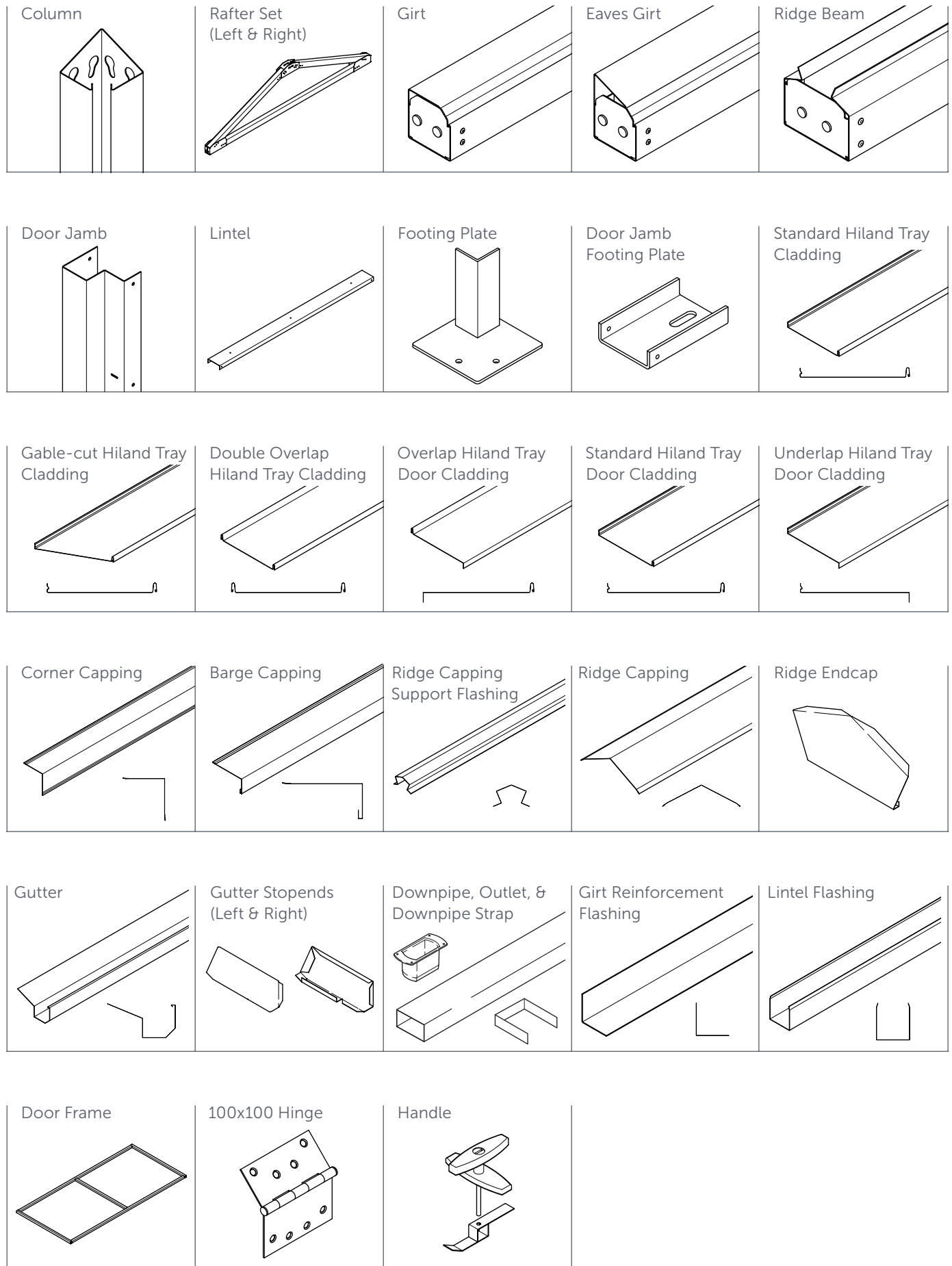

## COMPONENT DIAGRAM

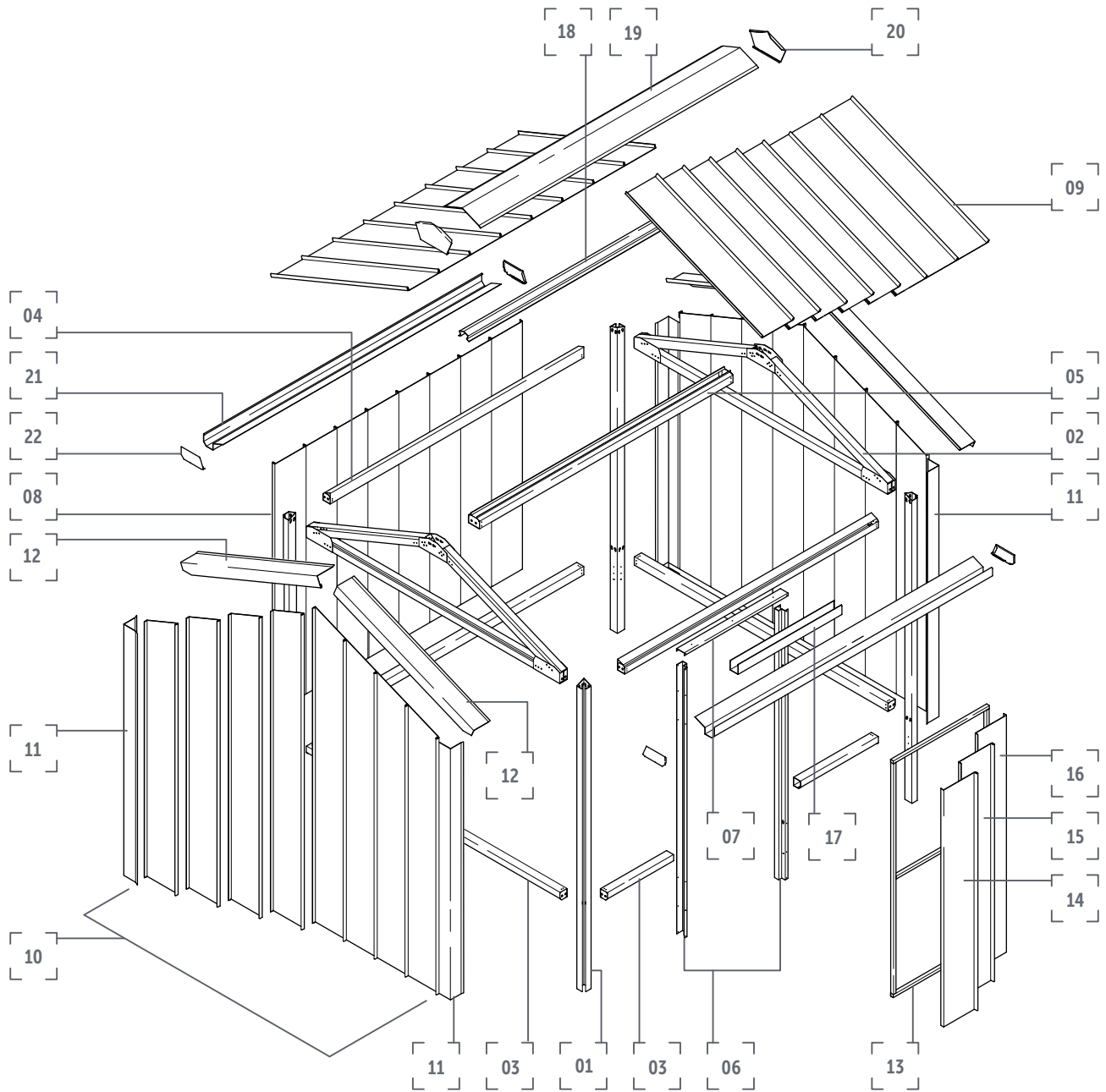

- |   |  |
|---|--|
| 1. Column                               | 13. Door Frame                           |
| 2. Rafter Set                           | 14. Hiland Tray Door Cladding (Overlap)  |
| 3. Girt                                 | 15. Hiland Tray Door Cladding (Standard) |
| 4. Eaves Girt                           | 16. Hiland Tray Door Cladding (Underlap) |
| 5. Ridge Beam                           | 17. Lintel Flashing                      |
| 6. Door Jambs                           | 18. Ridge Beam Support Flashing          |
| 7. Lintel                               | 19. Ridge Capping                        |
| 8. Hiland Tray Wall Cladding            | 20. Ridge Endcap                         |
| 9. Hiland Tray Roof Cladding            | 21. Gutter                               |
| 10. Hiland Tray Gable Cut Wall Cladding | 22. Gutter Stop end                      |
| 11. Corner Capping                      |  |
| 12. Barge Capping                       |  |

## LAYOUTS & PREPARATION

### COLUMN POSITIONING

If fixing the columns into the ground, mark out the footing-hole locations with stakes and check that the diagonal measurements are equal (refer to Figure 1.0 and Table 1.0).

| APPROX. DIAGONAL DIMENSIONS |        |        |        |
|-----------------------------|--------|--------|--------|
| H1                          | H2     | H3     | H4     |
| 3306mm                      | 3889mm | 4395mm | 4520mm |

TABLE 1.0

If the door positioning is known, it is best to dig the holes for the door jambs at this point, as it can be difficult to dig around the structure later in the process. Alternatively, if fixing to an existing concrete slab a bolted footing bracket is available. (Refer to section 'Securing Columns')

### DIGGING POST HOLES

Dig post holes as illustrated in Figure 1.1. Place a half brick in the bottom of the hole to ease settlement.

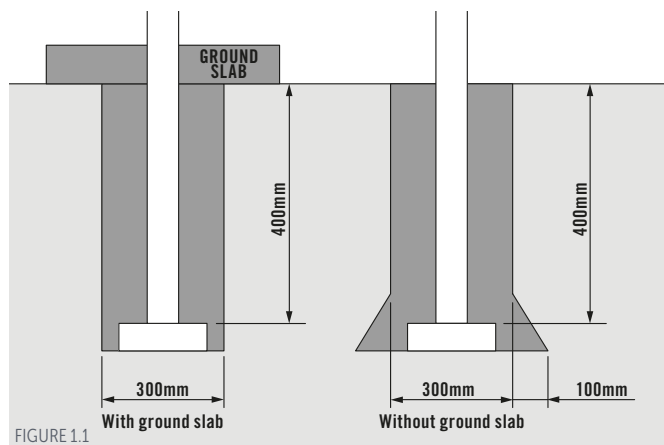

FIGURE 1.1

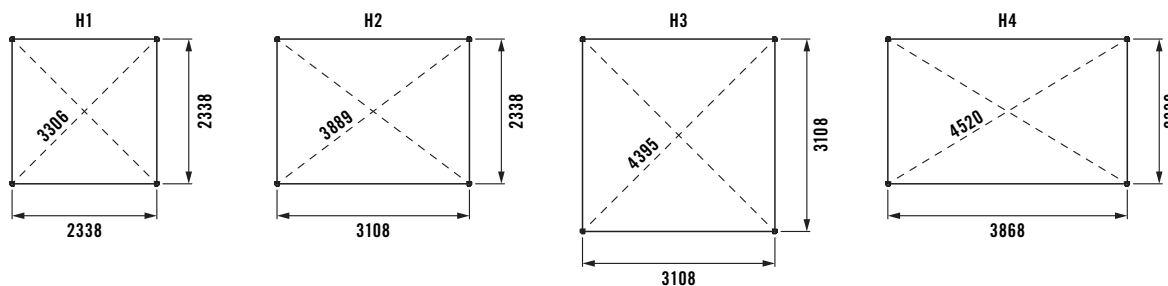

FIGURE 1.0

## GABLE END WALL CONSTRUCTION

### FRAMEWORK ASSEMBLY

Layout all wall structural components and ensure the correct orientation (Figure 2.0).

Note: All open faces must be facing up and in the correct direction. This will be the outside of the wall.

If the shed is being fixed to concrete the footing plates must be attached. Fit the footing plates to the columns using four 12x35mm self-drilling screws through the pilot holes provided (Figure 2.1). 3mm pilot holes can be created in the footing plate upright to make screw fixing easier.

Begin gable end framework assembly by fitting columns to rafter sets using the slot-&-lock details (Figure 2.2).

## CONCRETE SLAB PREPARATION

The extents of concrete slabs should align with the outside of shed columns.

Table 1.1 provides the approx. concrete slab dimensions required for each shed size.

| APPROX. CONCRETE SLAB DIMENSIONS |               |               |               |
|----------------------------------|---------------|---------------|---------------|
| H1                               | H2            | H3            | H4            |
| 2403 x 2403mm                    | 3173 x 2403mm | 3173 x 3173mm | 3933 x 2403mm |

TABLE 1.1

### COMPONENT PREPARATION

If the shed is going onto concrete the columns and door jambs must be cut back to the correct length.

Refer to the marking on the bottom of columns and door jambs to identify the cut location (Figure 1.2).

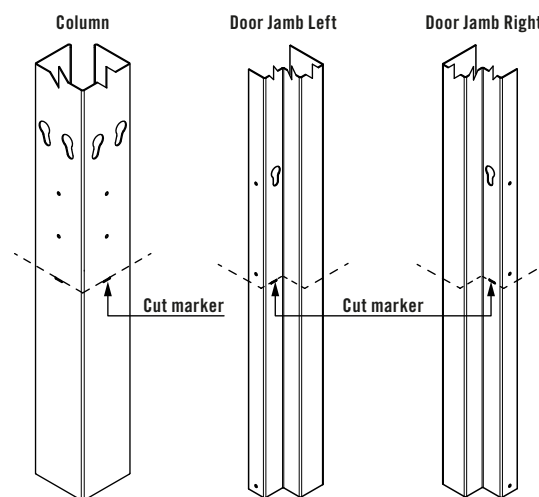

FIGURE 1.2

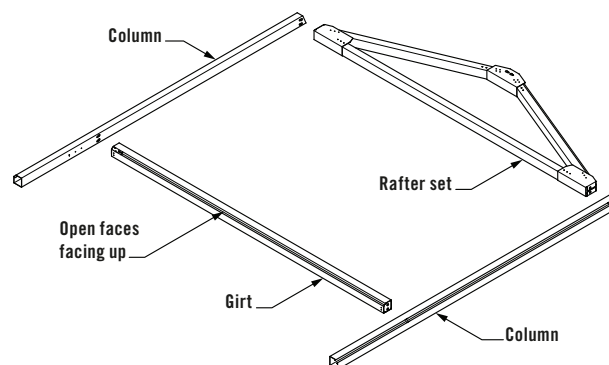

FIGURE 2.0

Assemble gable end girts to columns using the slot-&-lock keyways provided (Figure 2.3).



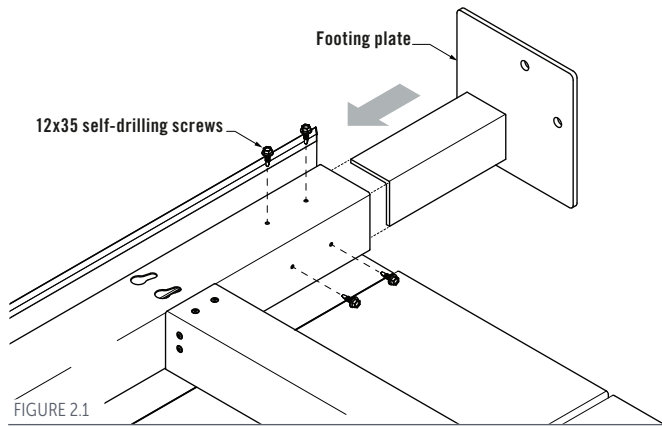

FIGURE 2.1

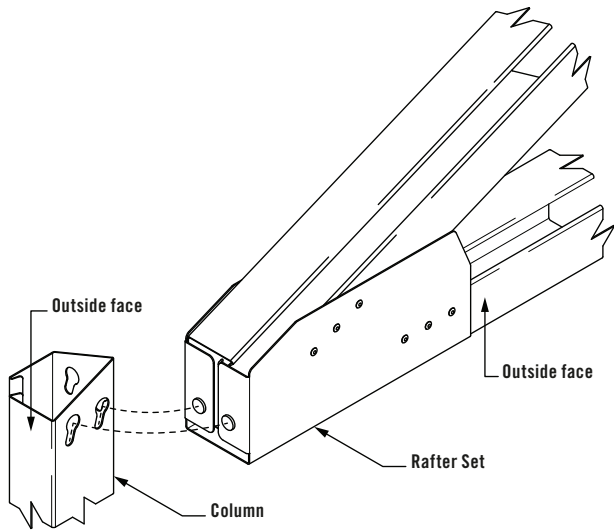

FIGURE 2.2

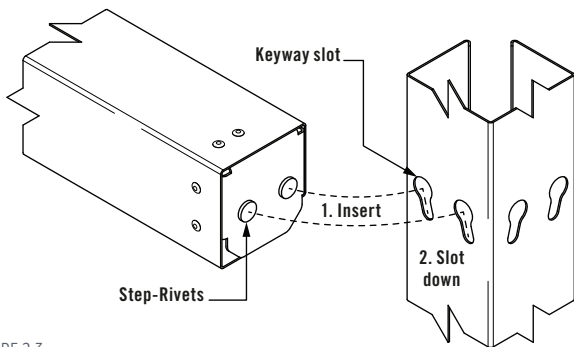

FIGURE 2.3

Ensure the framework is square by checking the diagonal measurements from the eaves to the end of the opposing column (Figure 2.4).

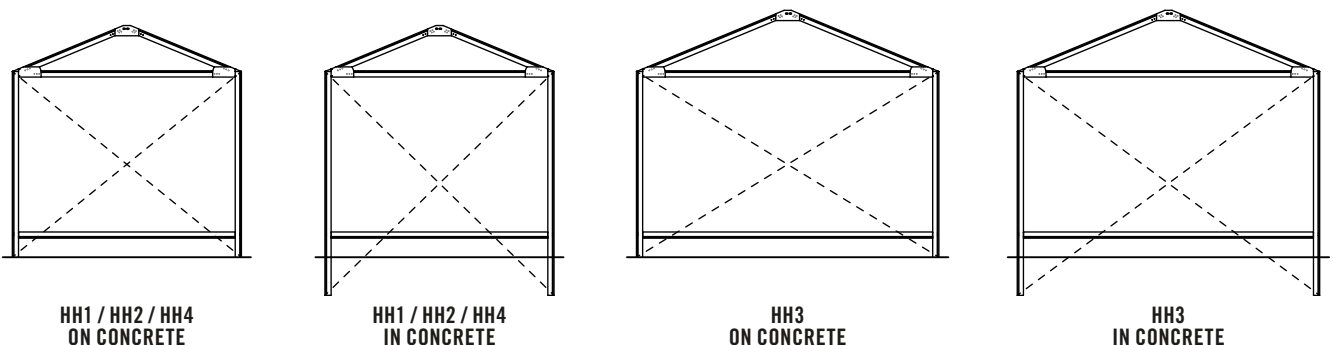
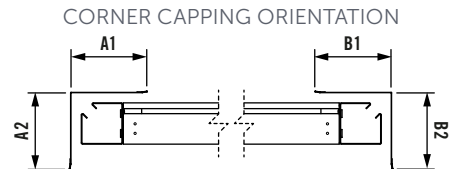

FIGURE 2.4

### CLADDING INSTALLATION

Note: Peel protective plastic from each cladding piece prior to installation.

Gable end wall cladding must be secured to the gable end framework before framework erection. Corner-capping is used to locate the cladding evenly and allow for sheet variation. Refer to Table 2.0 for corner capping layout dimensions.



|     | A1    | A2    | B1    | B2    |
|-----|-------|-------|-------|-------|
| HH1 | 152mm | 152mm | 152mm | 152mm |
| HH2 | 152mm | 125mm | 152mm | 125mm |
| HH3 | 262mm | 125mm | 262mm | 125mm |
| HH4 | 230mm | 152mm | 230mm | 152mm |

TABLE 2.0

Corner-capping must be trimmed back to suit the pitch of the gable end in HH3 Handi-Hilander garden shed. Use tin-snips to trim corner-capping (Figure 2.5).

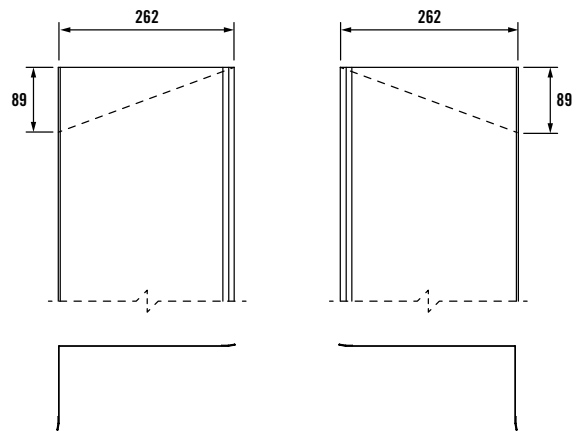

FIGURE 2.5

Fit the left-hand corner-capping over the column ensuring the capping sits hard against each side. Fix the corner-capping to the column using three evenly-spaced 10x16mm self-drilling screws (Figure 2.6 & 2.7). HH3 corner-capping will also require extra fixings at the girt, truss, & rafter (Figure 2.7). Repeat this process for the right-hand corner-capping.

# HANDI-HILANDER GARDEN SHED INSTALLATION GUIDE

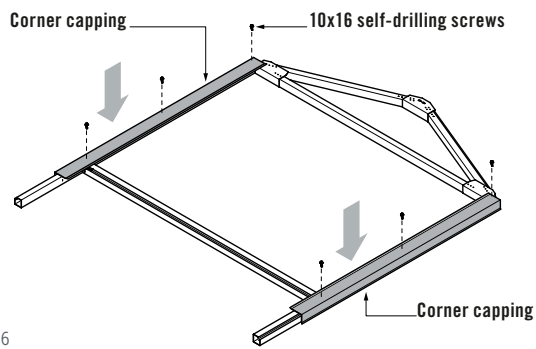

FIGURE 2.6

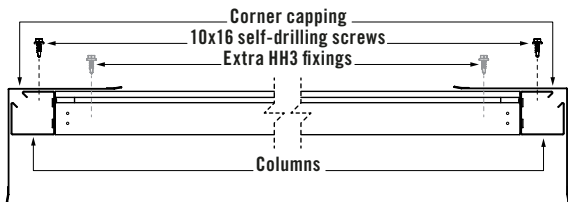

FIGURE 2.7

Gable wall cladding is provided pre-mitred and should be laid from left-to-right. Lay-out all gable end wall cladding to ensure the sheets are ordered correctly for installation (Figure 2.8).

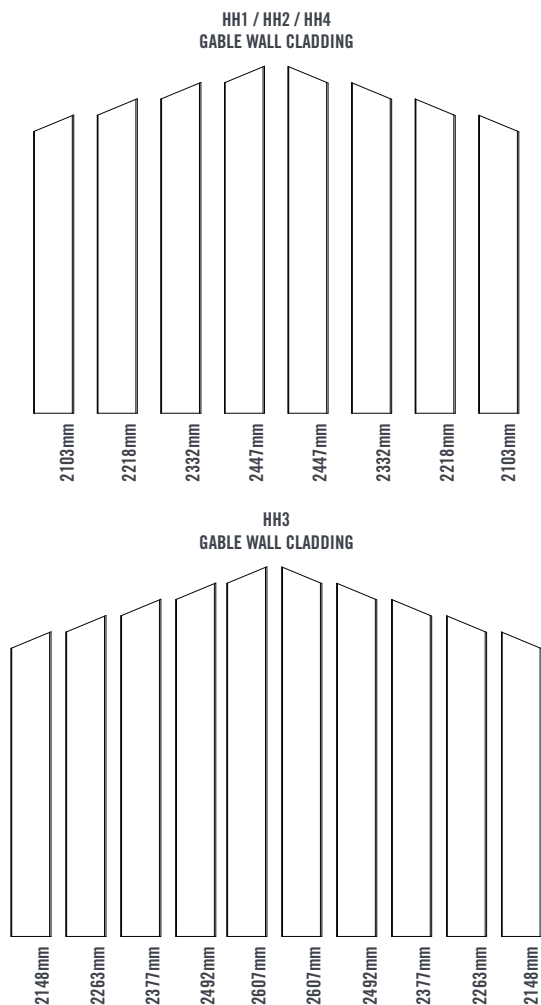

FIGURE 2.8

Position the first wall cladding sheet over the left corner-capping (Figure 2.9).

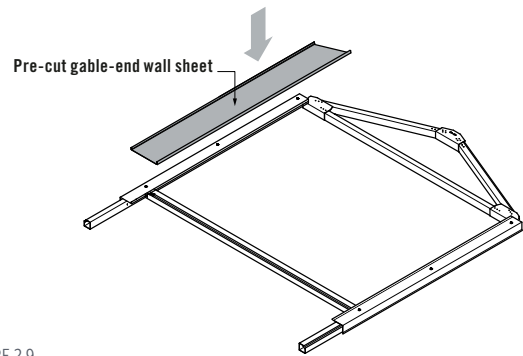

FIGURE 2.9

Secure cladding to framework using two 10x16mm self-drilling screws 20mm in from each rib at the rafter, truss, & lower girt (Figure 2.10).

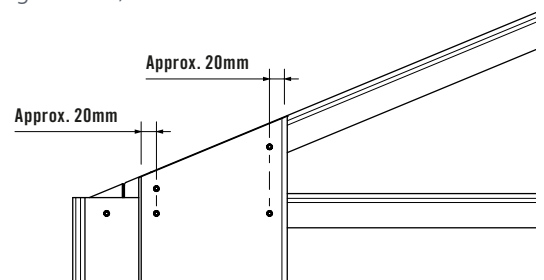

FIGURE 2.10

Install remaining wall cladding sheets without fixing to framework (Figure 2.11).

Check framework diagonals as sheets are being installed to ensure the framework remains square.

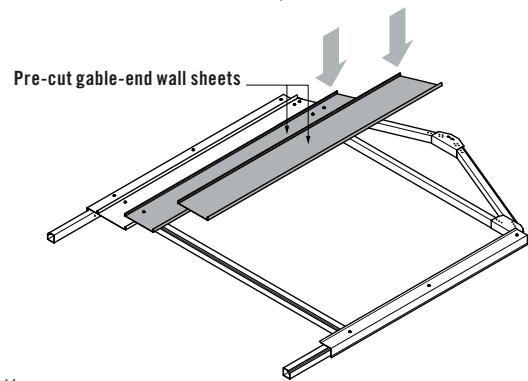

FIGURE 2.11

Once the entire framework has been clad the remaining sheets must be fixed in-place using two 10x16mm self-drilling screws 20mm in from each rib at the rafter, truss, & lower girt (Figure 2.12). String-line the rafters, truss, & girt to ensure screws are aligned.

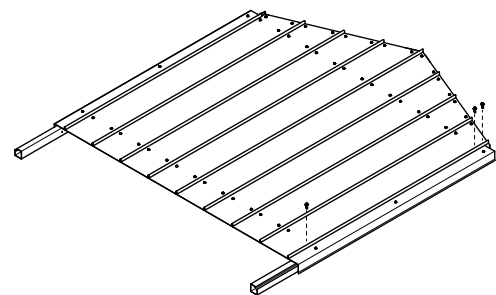

FIGURE 2.12

Repeat this process for the remaining gable end wall assembly.

## FRAMEWORK ERECTION

Gable end frames will need to be tilted into position. If fixing the columns into the ground carefully tilt each frame into position and place the columns into the footing holes (Figure 3.0) (refer LAYOUTS & PREPARATION). Temporarily brace in position.

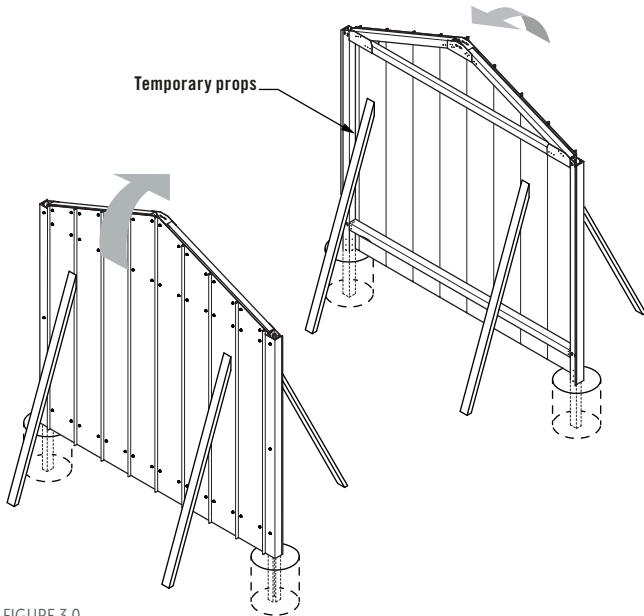

FIGURE 3.0

Connect the eaves girt to columns using slot-&-lock details (Figure 3.1). Repeat this step for remaining eaves girt.

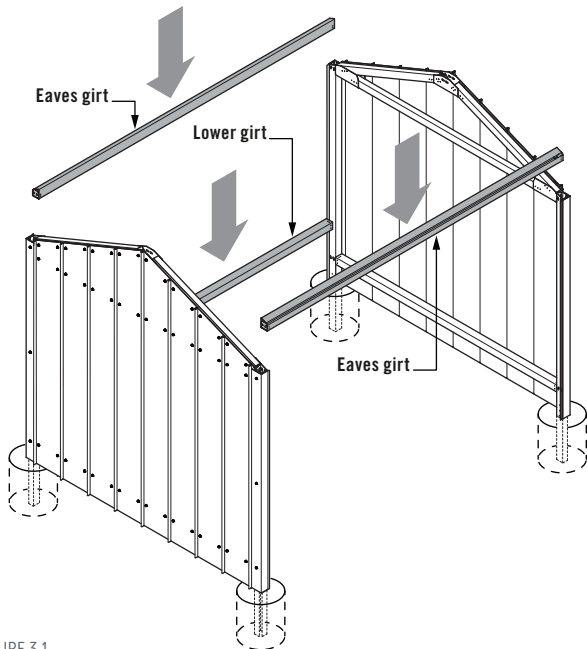

FIGURE 3.1

Install the lower girt between columns using the remaining slot-&-lock keyways on the opposite side to the intended door placement (Figure 3.1). Ensure the girt opening is facing outwards and down.

Note: All H2, H3, & H4 sheds will require lower girt reinforcement (Figure 3.2).

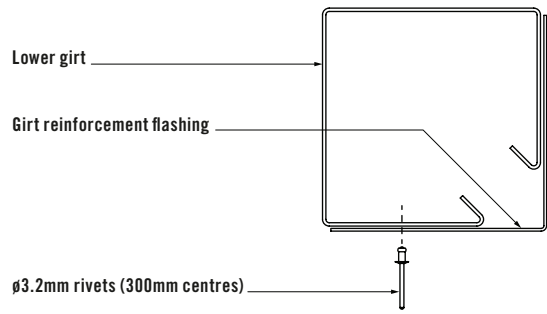

FIGURE 3.2

To prepare the ridge beam for installation, slide the ridge capping support flashing over the ridge beam (Figure 3.3).

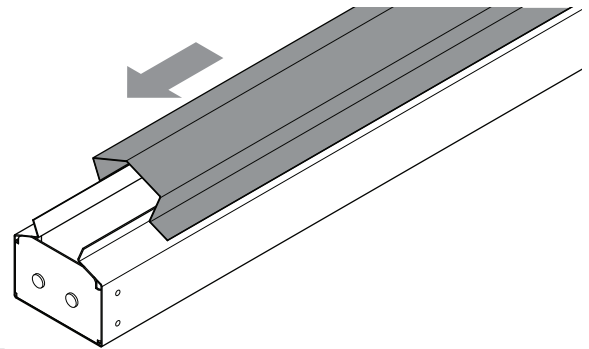

FIGURE 3.3

Connect the ridge beam between the rafter sets using the horizontally aligned slot-&-lock details (Figure 3.4 & 3.5).

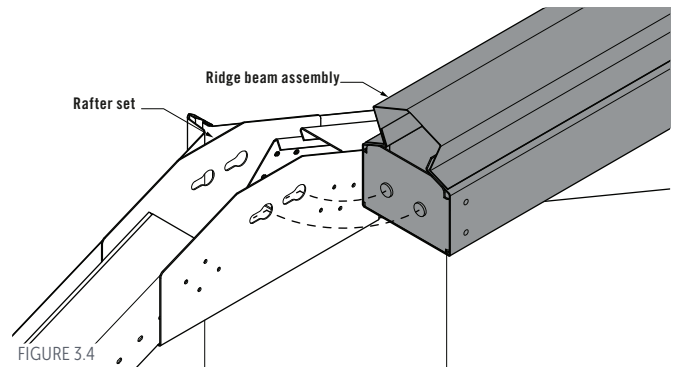

FIGURE 3.4

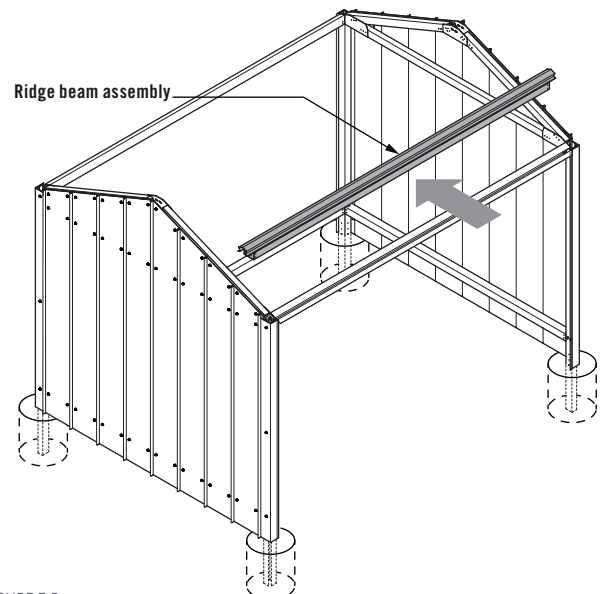

FIGURE 3.5

## DOOR JAMB INSTALLATION

A Double Door lintel is provided with each kit and will need to be cut-back for use with Handi-Hilander single doors. Cut-back the door lintel at the rectangular notch to achieve the required length of 930mm for a single door.

The door may be placed anywhere along the front wall at the discretion of the installer. Ensure the jambs are spaced at a minimum distance of one walling panel in from the column as advised in Table 3.0 & Figure 3.0.

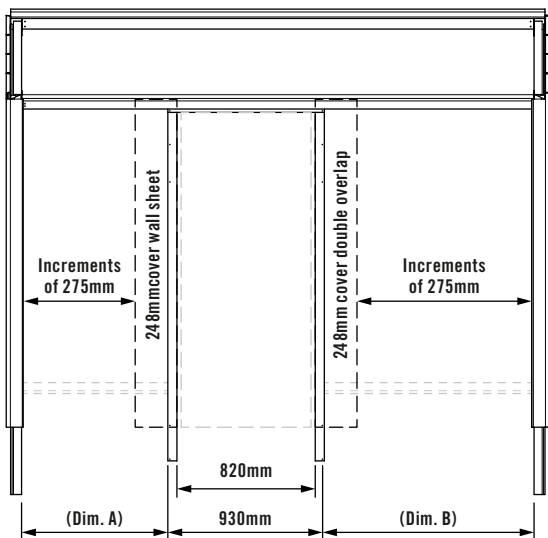

FIGURE 3.0

LINTEL SPACING (PAIRS)

|     | A   | B    | A   | B    |     |      |      |      |
|-----|-----|------|-----|------|-----|------|------|------|
| HH1 | 259 | 1086 | 534 | 811  |     |      |      |      |
| HH2 | A   | B    | A   | B    | A   | B    | A    | B    |
| HH3 | 228 | 1886 | 503 | 1611 | 778 | 1336 | 1052 | 1062 |
| HH4 | A   | B    | A   | B    | A   | B    | A    | B    |
|     | 331 | 2544 | 606 | 2269 | 881 | 1994 | 1156 | 1719 |
|     |     |      |     |      |     |      | 1431 | 1444 |

TABLE 3.0

NOTE: ALL DIMENSIONS IN MM.  
DIMENSION PAIRS CAN BE REVERSED FOR LEFT & RIGHT DOOR PREFERENCES.

Install the door lintel using 10x16mm self-drilling screws through the pilot holes provided. Note: The door lintel must be positioned centrally beneath the eave girt (Figure 3.1).

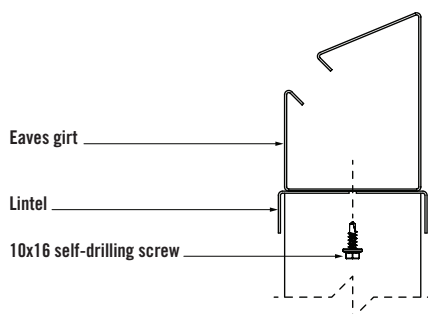

FIGURE 3.1

Install door jambs to the lintel using 10x16mm self-drilling screws through the internal pilot holes provided, and 10x16mm wafer-head self-drilling screws externally (Figure 3.2).

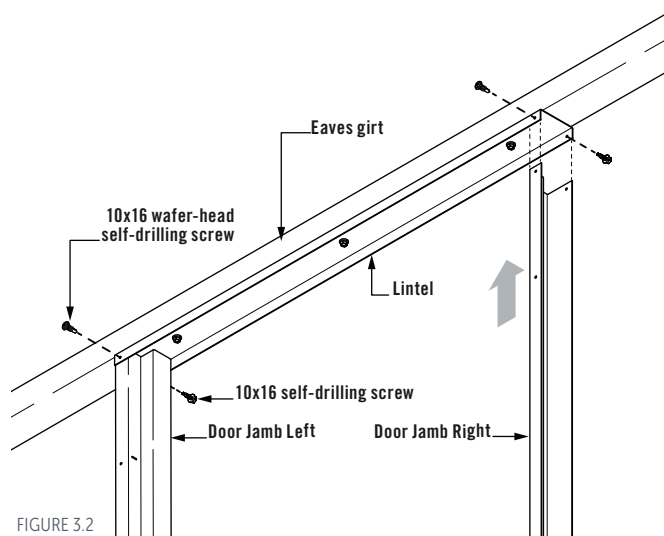

FIGURE 3.2

Full length lower girts have been provided for each side wall. One lower girt will need to be cut back to create two smaller girts to fit between columns & jambs (Figure 3.3).

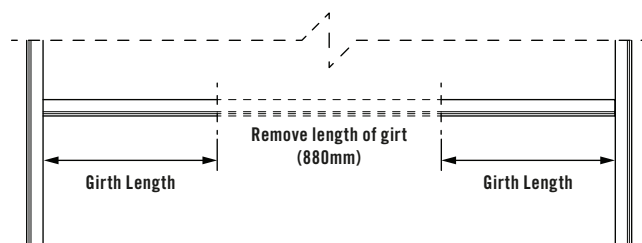

FIGURE 3.3

Lay-out the girt alongside the shed to ensure correct orientation of slot-&-lock endcaps before marking and cutting. Measure the distance between the inside face of the column and inside of the door jamb and cut back the girt accordingly. To allow for correct jamb spacing a gap of approx. 880mm must be removed from the girt.

Fit door girts between the columns and door jambs using the slot-&-lock keyways provided at the column (Figure 3.4).

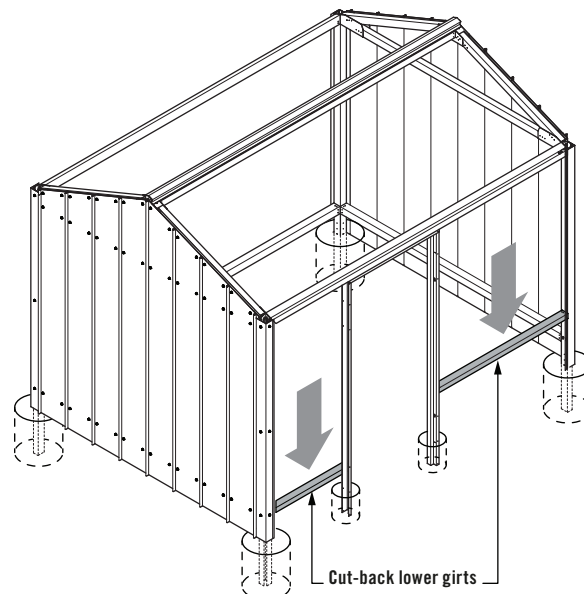

FIGURE 3.4

The cut-back ends of the girts will require fixing to door jambs using 10x16mm self-drilling screws through the internal door jamb pilot holes, and 10x16mm wafer-head screws through the external door jamb pilot holes (Figure 3.5).

Note: If the shed is fixed to concrete, two footing brackets for door jambs will be required. Ensure the holes for masonry anchors are pre-drilled before wall cladding installation. Do not secure jambs to concrete at this stage of installation.

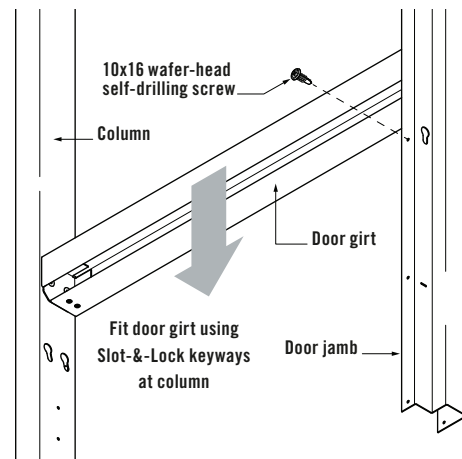

FIGURE 3.5

## CLADDING INSTALLATION

Before installing wall cladding, ensure the framework is square by checking diagonals (Figure 1.0). Also use a spirit level to ensure all columns are vertical.

### REAR WALL CLADDING

Begin cladding the rear wall by positioning a wall sheet over the corner capping underlap (Figure 4.0).

Note: Peel protective plastic from each cladding piece prior to installation.

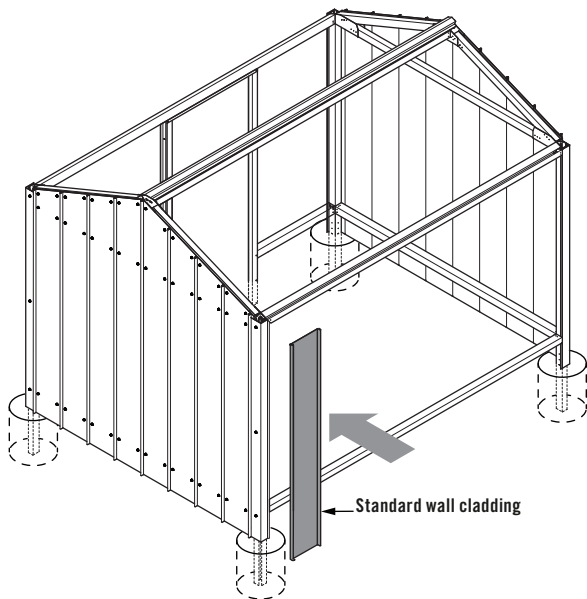

FIGURE 4.0

Use a spirit level to ensure the first sheet is vertical, then secure the corner-capping to the column at each end and mid-span, and wall cladding using two 10x16mm self-drilling screws 20mm in from each rib at the eaves & lower girts (Figure 4.1).

Extra 10x16mm self-drilling screws will be required for HH4 corner-capping along the eaves girt & lower girt.

Continue installing wall sheets along the length of the wall, fixing using two 10x16mm self-drilling screws 20mm in from each rib at the eaves & lower girts (Figure 4.2).

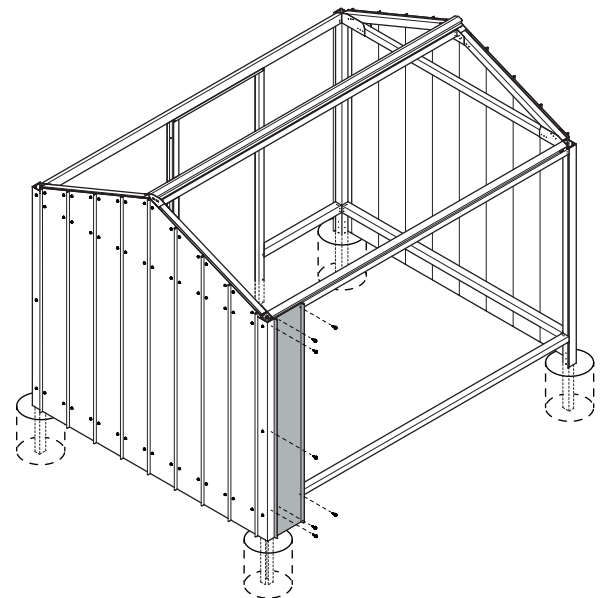

FIGURE 4.1

Use a string line along the outside face of the wall cladding to maintain an even and horizontal placement of screws.

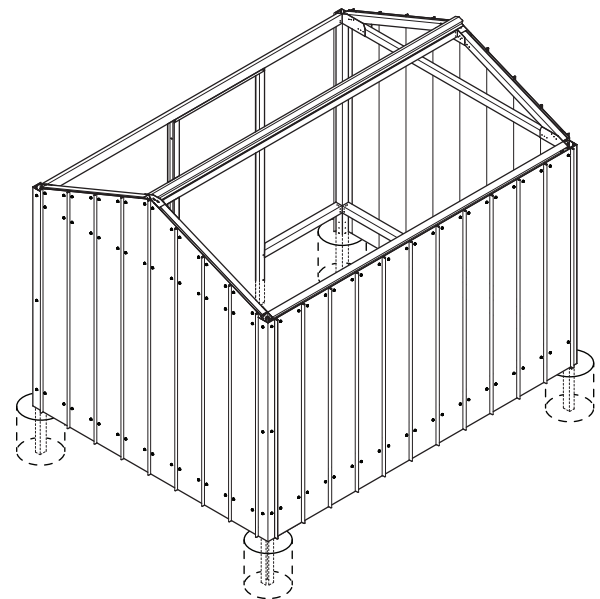

FIGURE 4.2



### FRONT WALL CLADDING

Wall cladding must be installed from the corner capping at each end of the wall and up to the door jambs. Slide each wall sheet down the previous underlap or overlap, and secure using two 10x16mm self-drilling screws 20mm in from each rib at the eaves & lower girts (Figure 4.3).

Narrower wall sheets (248mm cover) are provided to fit adjacent door jambs. One 248mm cover standard sheet and one 248mm cover double-overlap sheet has been provided to ensure that the run of cladding finishes with an overlap rib at each side of the door (Figure 4.3 & 4.4).

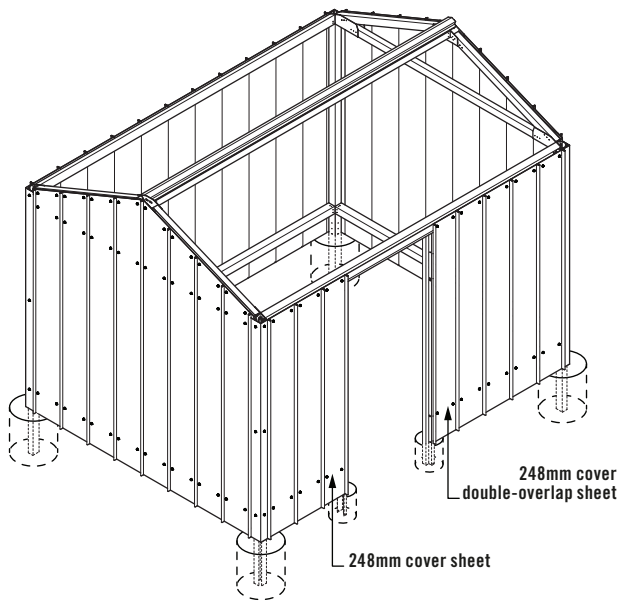

FIGURE 4.3

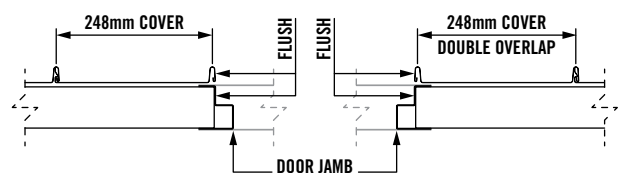

FIGURE 4.4

### DOOR FLASHING

The door lintel flashing is to cover the door lintel and is secured through the front face using at least two colour-matched rivets (Figure 4.5). The door lintel flashing must be notched around door jambs (Figure 4.6).

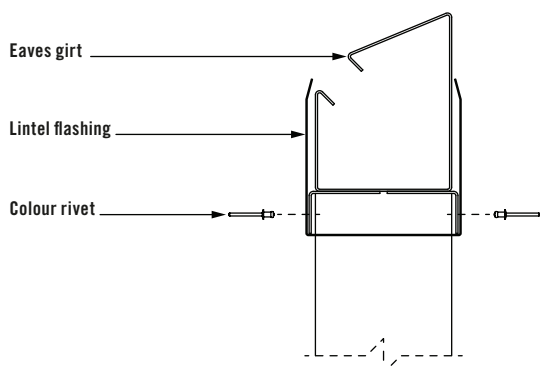

FIGURE 4.5

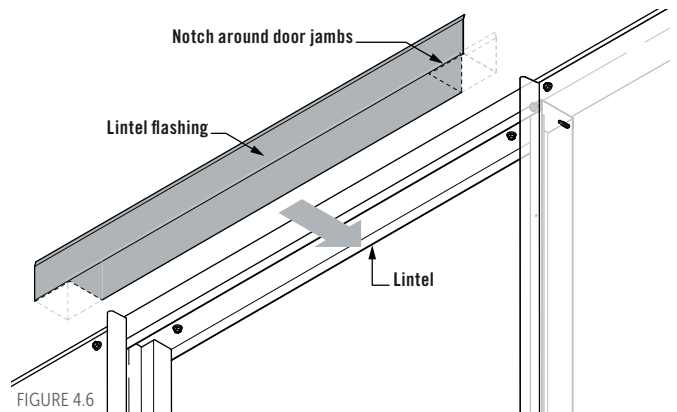

FIGURE 4.6

### ROOF CLADDING

Barge capping is used to determine the starting positioning of roof cladding to ensure roof cladding aligns with wall cladding. Each barge cap must be notched to allow for clearance when later attaching gutters. Place each barge cap in their intended location before notching to ensure notches are made at the correct end. Barge capping must sit over rafters and on the outside of gable wall cladding ribs. Notch the vertical face of each barge cap using tin-snips (Figure 4.7).

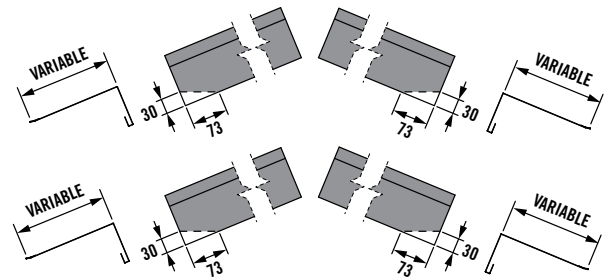

FIGURE 4.7

Ensure barge capping is parallel to the rafter and against gable wall cladding. Fix barge capping through to the top of the rafter using three 10x16mm self-drilling screws (with neoprene washers) (Figure 4.8).

Recommended that a bead of silicone is applied across the underside of the Barge Capping (squash fold end) to create a seal between the Barge Capping and Roof Sheet.

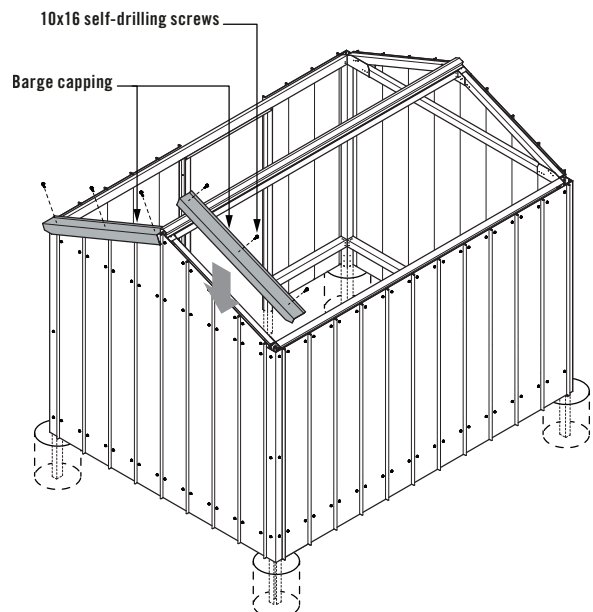

FIGURE 4.8

Position the first roof sheet along the fold on the barge cap (Figure 4.9).

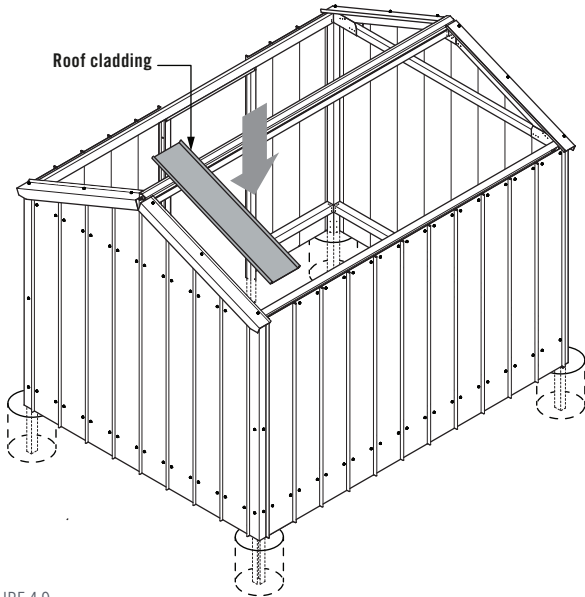

FIGURE 4.9

Fix the roof sheet through to the ridge beam using two 10x16mm self-drilling screws (with neoprene washers) 20mm in from each rib (Figure 4.10). Do not secure roof cladding to the eaves girt.

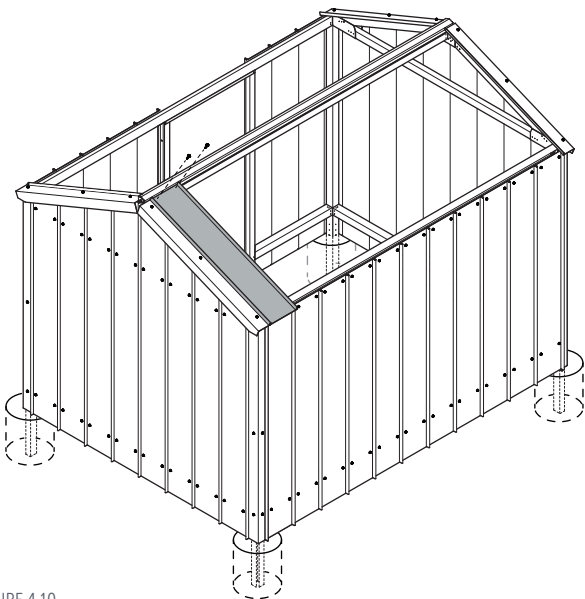

FIGURE 4.10

Continue this process along the roof.

Fit the overlap barge cap to finish the run of roof sheets. Fix the barge cap to the rafter using three 10x16mm self-drilling screws (with neoprene washers) (Figure 4.8). Repeat the roof cladding process on the remaining side of the shed.

### RIDGE CAPPING

Place the ridge capping atop the ridge support flashing and roof sheets. Secure ridge capping through to the ridge support flashing using 10x16mm self-drilling screws (with neoprene washers) alongside every second rib (Figures 4.11 & 4.12).

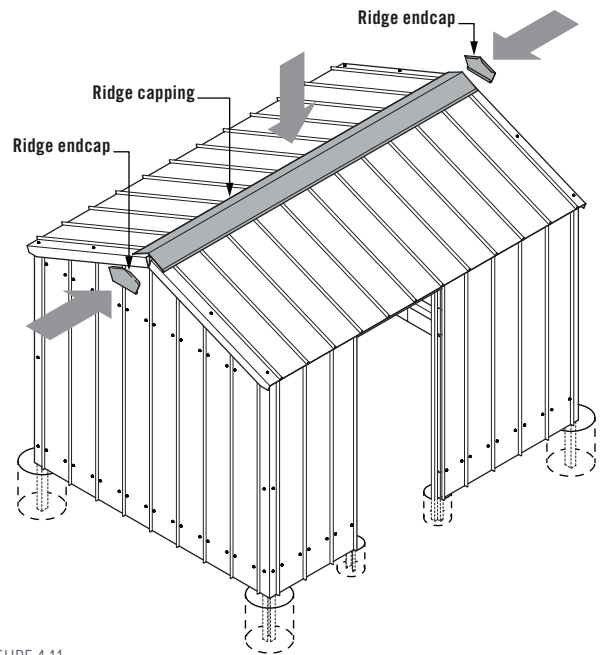

FIGURE 4.11

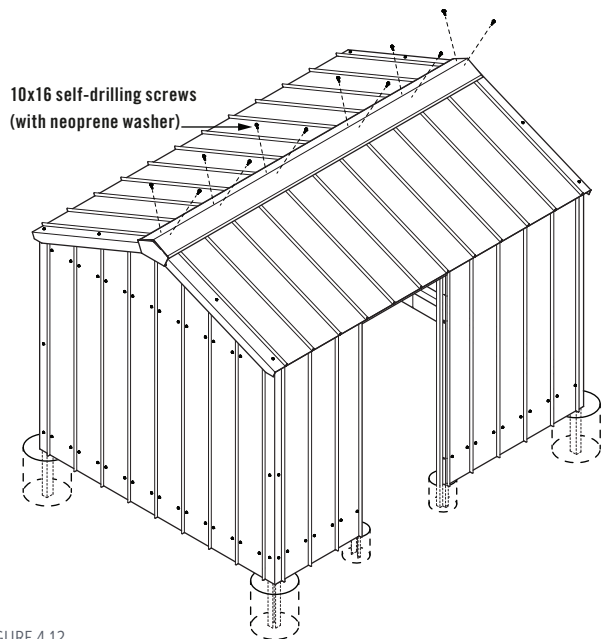

FIGURE 4.12

Note: Handi-Hilander roofing is non-trafficable. Secure ridge capping at each end for as far as you can safely reach. Complete the ridge capping by fitting a ridge endcap at each end of the ridge capping. Ridge endcaps will sit over the ridge cap & barge capping. Fix the ridge endcap using eight colour-matched rivets (Figure 4.11 & 4.13).

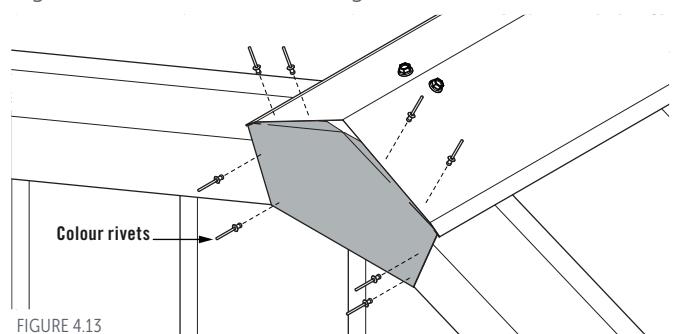

FIGURE 4.13

## GUTTER INSTALLATION

### GUTTER PREPARATION

Gutter stop-ends are supplied to cap the end of each gutter. Gutters are supplied at the correct length. Fit gutter stop-ends to the ends of the gutter. Drill  $\varnothing 3.5\text{mm}$  pilot holes through the gutter and stop-ends and fix together using colour-matched rivets (Figure 5.0).

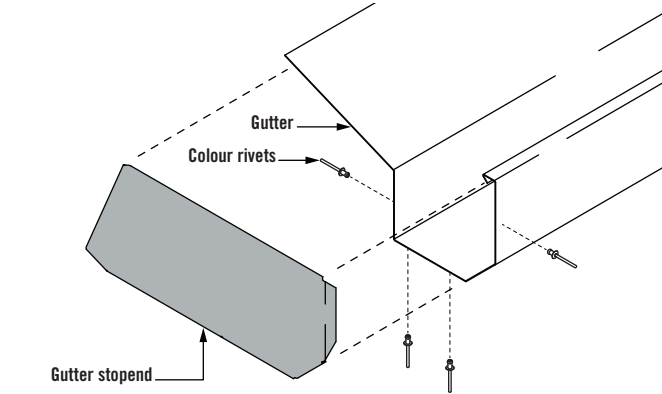

FIGURE 5.0

Note: Do not remove protective plastic until fitting the gutters in-place.

Determine the desired downpipe location by measuring in from the outside face of the barge capping (Figure 5.1).

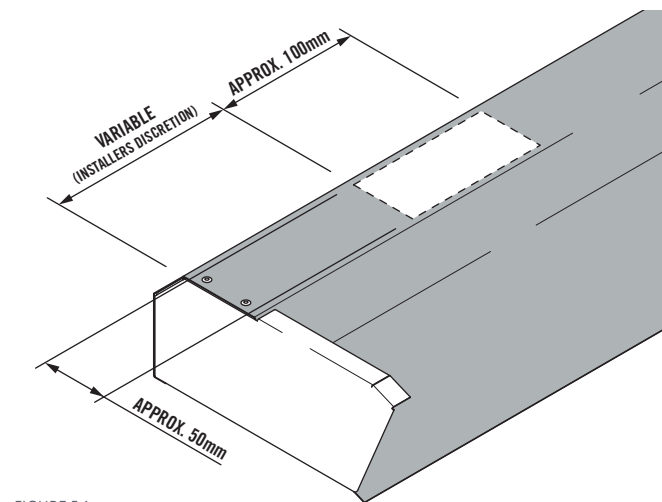

FIGURE 5.1

Reproduce the downpipe location on the base of the gutter and mark-out using pen. Cut the outlet hole in the base of the gutter using a power-drill & tin-snips.

Insert the downpipe outlet through the opening. Drill  $\varnothing 3.5\text{mm}$  pilot holes in the gutter through the holes in downpipe outlet. Secure the outlet to the gutter using four colour-matched rivets (Figure 5.2).

To prevent any leaks, silicone around the downpipe outlet & stop-ends inside the gutter.

Repeat the process for the remaining gutter.

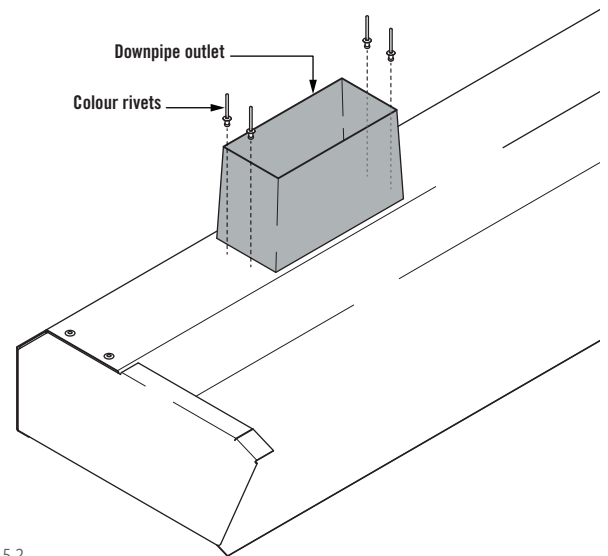

FIGURE 5.2

### GUTTER INSTALLATION

Lift the gutter assembly into place and slide between the roof cladding and eaves girt. Gutter stop-ends must sit over the barge capping at each end.

Secure gutters in-place using two 10x16mm self-drilling screws (with neoprene washer) through each roof sheet (Figure 5.3). Screws must be positioned approx. 85mm in from the end of roof sheets, and approx. 20mm in from each rib.

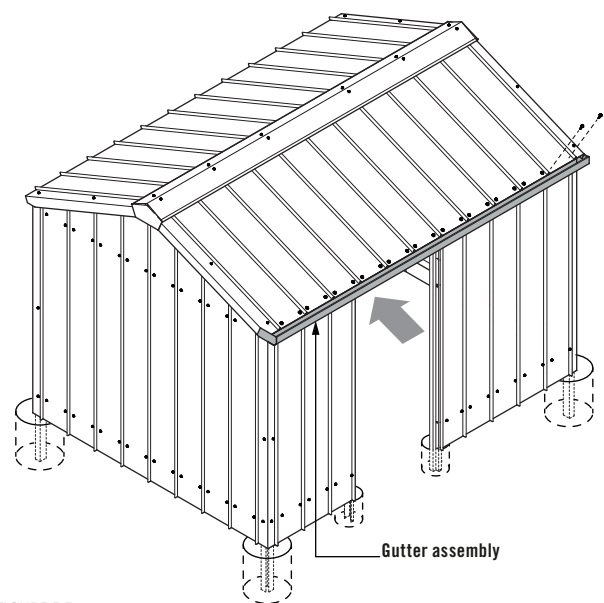

FIGURE 5.3

Drill two  $\varnothing 3.5\text{mm}$  pilot holes through the gutter stop-ends and barge capping and secure through the outside face using colour-matched rivets.

Fix the downpipe strap to wall cladding & lower girt below the downpipe outlet using two 10x16mm self-drilling screws.

Fit the downpipes to the downpipe outlets and secure using two 10x16mm self-drilling screws through each side of the downpipe.

Drill two  $\varnothing 3.5\text{mm}$  pilot holes through the downpipe strap & downpipe and secure using colour-matched rivets.

## DOOR INSTALLATION

### DOOR PREPARATION

Lay-out the door frame provided on a flat surface. Fit the underlap door sheet to the door frame and secure using 10x16mm self-drilling screws through to the horizontal door frame members (approx. 20mm in from the each side) (Figure 6.0 & 6.1). Drill five evenly-spaced  $\varnothing 3.5\text{mm}$  pilot holes through the side laps of the door sheet & door frame and fix using rivets (Figure 6.1)

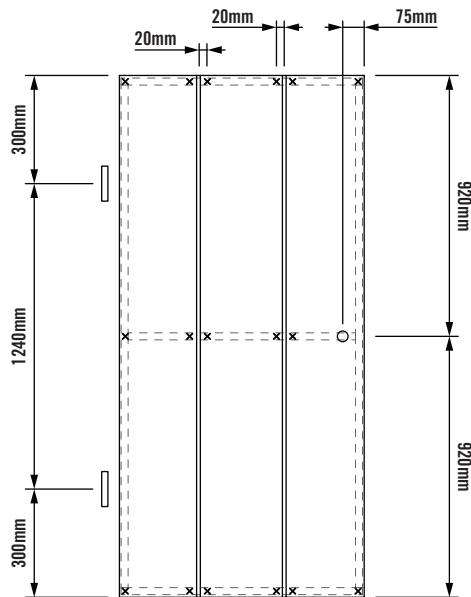

FIGURE 6.0

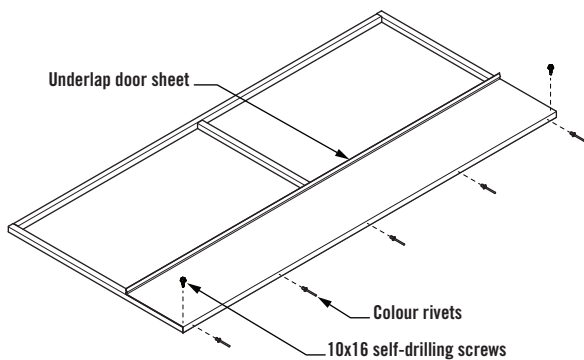

FIGURE 6.1

Slide the remaining two door sheets into place and fix using 10x16mm self-drilling screws through to the horizontal door frame members (approx. 20mm in from the each side) (Figure 6.2 & 6.3). Rivet the side lap of the overlap sheet as per the underlap (Figure 6.3)

Drill one  $\varnothing 12\text{mm}$  hole through the door cladding & door frame 75mm in from the side of the door (Figure 6.4). Insert the T-handle through the hole and fix the handle to the horizontal door-frame member using the self-drilling screws provided in the framework kit (Figure 6.4).

Two pairs of hinges have been supplied with the Handi-Hilander garden shed. Discard the hinges from the framework kit and use the larger hinges that have been provided separately.

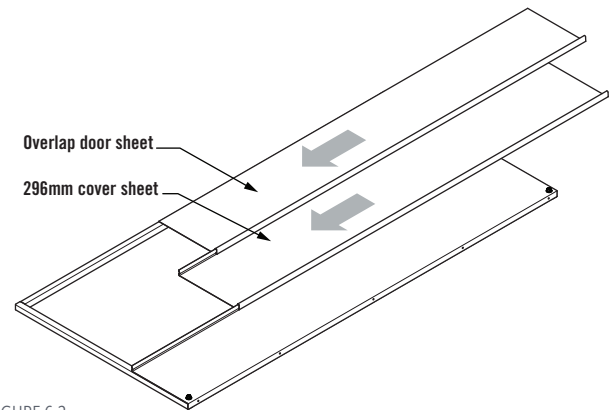

FIGURE 6.2

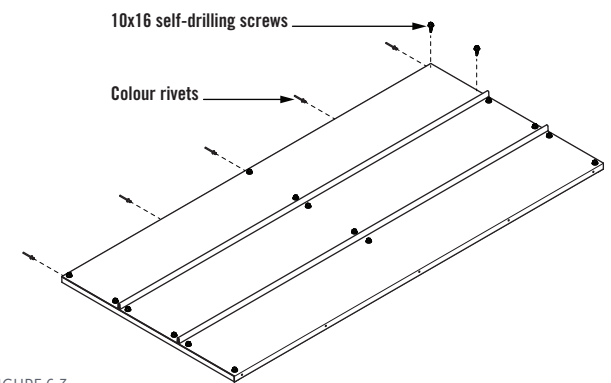

FIGURE 6.3

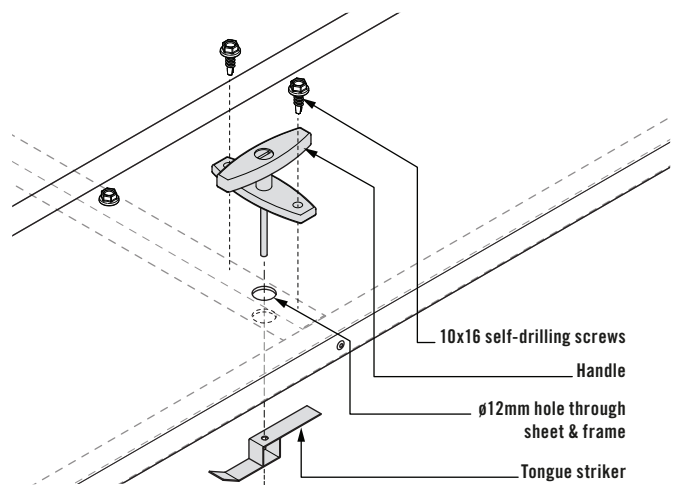

FIGURE 6.4

Fix the hinges to the door frame using two 10x16mm wafer-head self-drilling screws (Figure 6.5). Hinges must be flush with the internal face of the door frame.

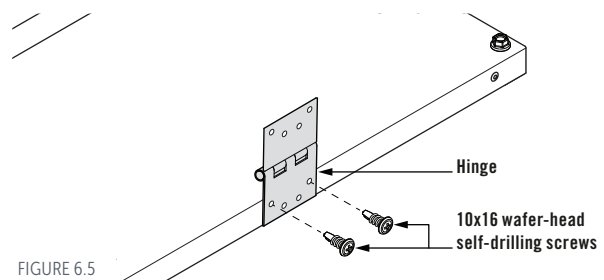

FIGURE 6.5

### HANGING THE DOOR

Fix the door hinges to the door jamb using two 10x16 wafer head screws whilst ensuring an even gap is created above and below the door.

## SECURING SHED TO CONCRETE

When the unit is square and level in its finalised position secure all footing plates to the ground using  $\varnothing 10\text{mm}$  masonry anchors (Figure 7.0).

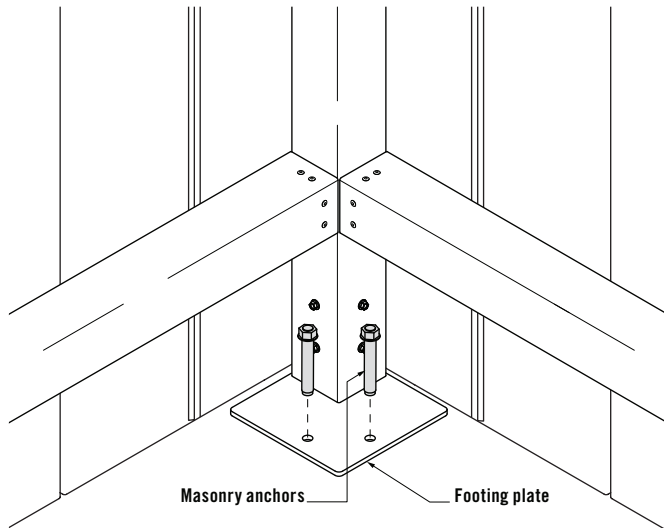

FIGURE 7.0

Fix the door jamb footings to the slab using one masonry anchor per footing (Figure 7.1).

Note: Concrete is to have a minimum strength of 20MPa.

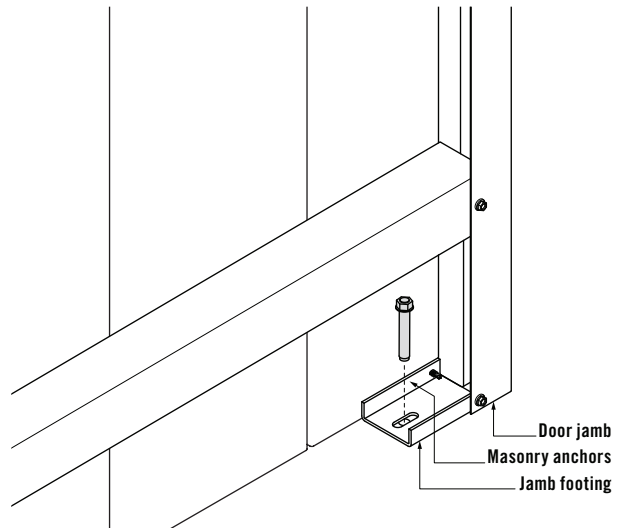

FIGURE 7.1

## MAINTENANCE

Your Stratco Handi-Garden Shed will maintain its good looks for even longer with a simple wash and wipe down. Cleaning should be performed as often as is required to remove any dirt, salt and pollutants. Stratco Handi-Sheds are produced from the highest quality materials and will provide many years of service, refer to the 'Selection Use and Maintenance' brochure for more information on how to get the best out of your product.





NOTES:

---

---

---

---

---

---

---

---

---

---



« SCAN THIS QR CODE TO FIND A STRATCO NEAR YOU

**1300 155 155**  
**stratco.com.au**

All brands and logos/images accompanied by © or ™ are trade marks of Stratco (Australia) Pty Limited. © Copyright June 2019

**How To.**

